

Think GAIA  
For Life and the Earth

**SANYO**

## Discrete Devices

2008-6



# Power & RF Devices

**SANYO Semiconductor Co., Ltd.**



# SANYO Discrete Devices

SANYO's environmentally-considered discrete "ECoP" contributes to the realization of comfortable life in various aspects.

## Contents

■ Devices for Mobile Equipment	p2
■ Devices for SW Power Supply	p14
■ Devices for Lighting	p28
■ Devices for Modem	p31
■ Devices for Infrared Sensor	p31
■ Devices for Satellite/GPS	p32
■ FM Transmitter	p33



**Invisible**

Ultra-small  
Thin-form  
Light-weight

**Friendly**

High-efficient  
Energy-saving

**Smart**

Multi-function  
High-performance  
High-integration



Environmentally Considered Products

We provide discrete solutions based on "**LIGHT, FAST, EFFICIENT & FRIENDLY**" concept to contribute to the creation of "Symbiosis Next-generation Electronic Devices" aiming at the realization of better life.

# Power & RF Devices

## Application Block

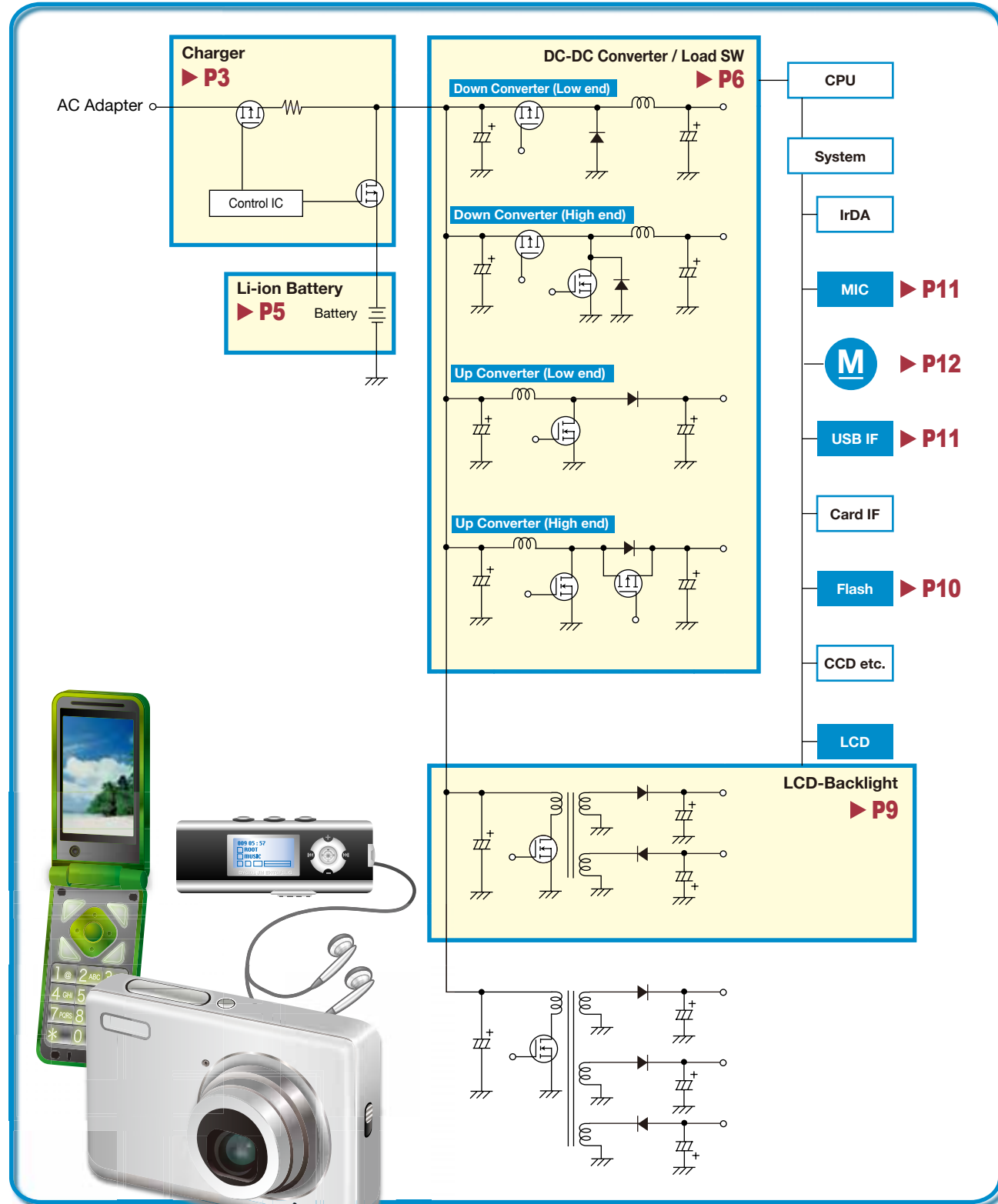

## Charger

[GSM]

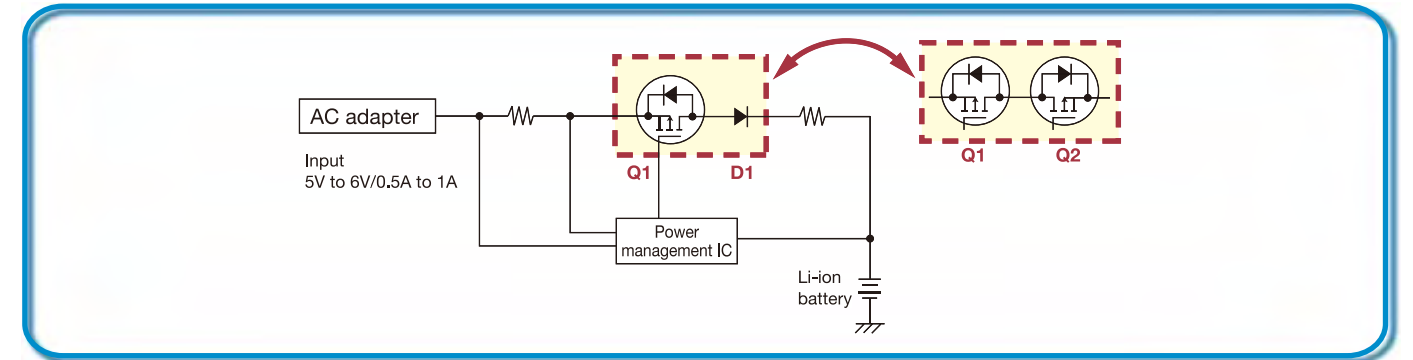

## MOSFETs (Pch) + Schottky Barrier Diodes (or MOSFETs (Pch))

※: Development

	Type No.	Package	2 in 1	Absolute maximum ratings/Ta=25°C				Electrical characteristics/Ta=25°C				
				VDSS/ VR [V]	VGSS [V]	ID/ IO [A]	PD [W]	RDS(on) [Ω] VGS=2.5V		VF [V]		
								typ	max	IF [A]	typ	max
Q1+D1	CPH5802	CPH5	Pch MOS	20	±10	2	0.9	0.140	0.200	-	-	-
			SBD	15	-	1	-	-	-	1	0.35	0.4
	VEC2822	VEC8	Pch MOS	20	±10	3.5	1	0.077	0.108	-	-	-
			SBD	15	-	2	-	-	-	2	0.5	0.56
Q1+Q2	VEC2303	VEC8	Pch MOS	12	±8	4	0.9	0.054	0.075	-	-	-
	VEC2301		Pch MOS	20	±10	3	0.9	0.087	0.120	-	-	-
	ECH8654	ECH8	Pch MOS	20	±10	5	1.3	0.041	0.058	-	-	-
	ECH8611		Pch MOS	12	±9	5	1.3	0.045	0.065	-	-	-
	* ECH8652		Pch MOS	12	±10	6	1.3	0.031	0.045	-	-	-

[CDMA]

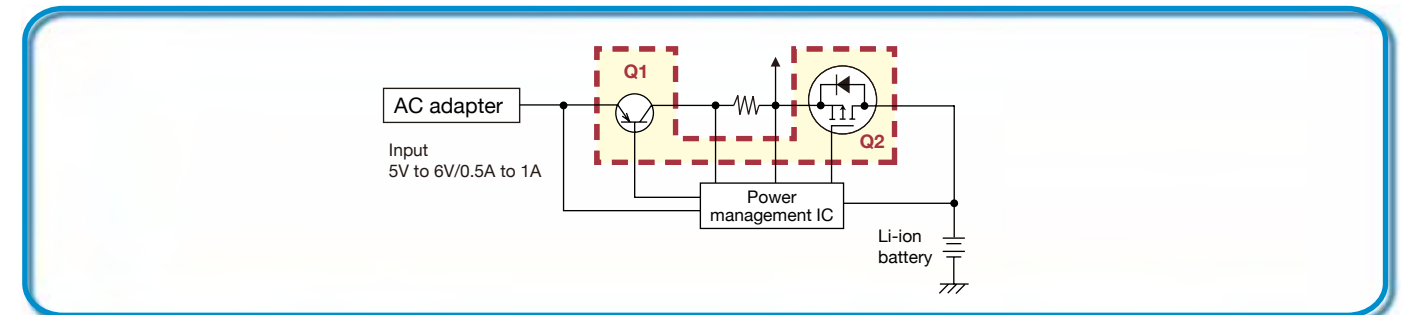

## Transistors (PNP) + MOSFETs (Pch)

※: Development

	Type No.	Package	2 in 1	Absolute maximum ratings/Ta=25°C			Electrical characteristics/Ta=25°C						
				VCEO/ VDSS [V]	IC/ ID [A]	PC Pd [W]	VCE(sat) [V]				RDS(on) [Ω] VGS=2.5V		
							IC [A]	IB [mA]	typ	max	typ	max	
Q1+Q2	VEC2904	VEC8	PNP TR	30	3	1.1	1.5	75	0.11	0.16	-	-	
			Pch MOS	12	4	1.1	-	-	-	-	0.054	0.074	
	VEC2905	VEC8	PNP TR	30	3	1.1	1.5	75	0.11	0.16	-	-	
			Pch MOS	20	3	1.1	-	-	-	-	0.087	0.120	
Q1	CPH6122	CPH6	PNP TR	30	3	1.3	1.5	75	0.120	0.180	-	-	
	* MCH6122	MCPH6	PNP TR	30	3	1.0	1.5	75	0.120	0.180	-	-	
	* VEC1106	VEC8	PNP TR	30	5	1.4	1.5	75	0.105	0.155	-	-	
Q2	MCH6320	MCPH6	Pch MOS	12	5	1.5	-	-	-	-	-	0.047	0.066
	MCH6321		Pch MOS	20	4	1.5	-	-	-	-	-	0.072	0.098
	MCH6336		Pch MOS	12	5	1.5	-	-	-	-	-	0.047	0.066
	MCH6337	ECH8	Pch MOS	20	4.5	1.5	-	-	-	-	-	0.053	0.075
	ECH8304		Pch MOS	12	9.5	1.6	-	-	-	-	-	0.018	0.026
	ECH8301		Pch MOS	20	8	1.6	-	-	-	-	-	0.026	0.037
EMH1303	EMH8	Pch MOS	12	7	1.5	-	-	-	-	-	0.027	0.036	



## [CDMA]

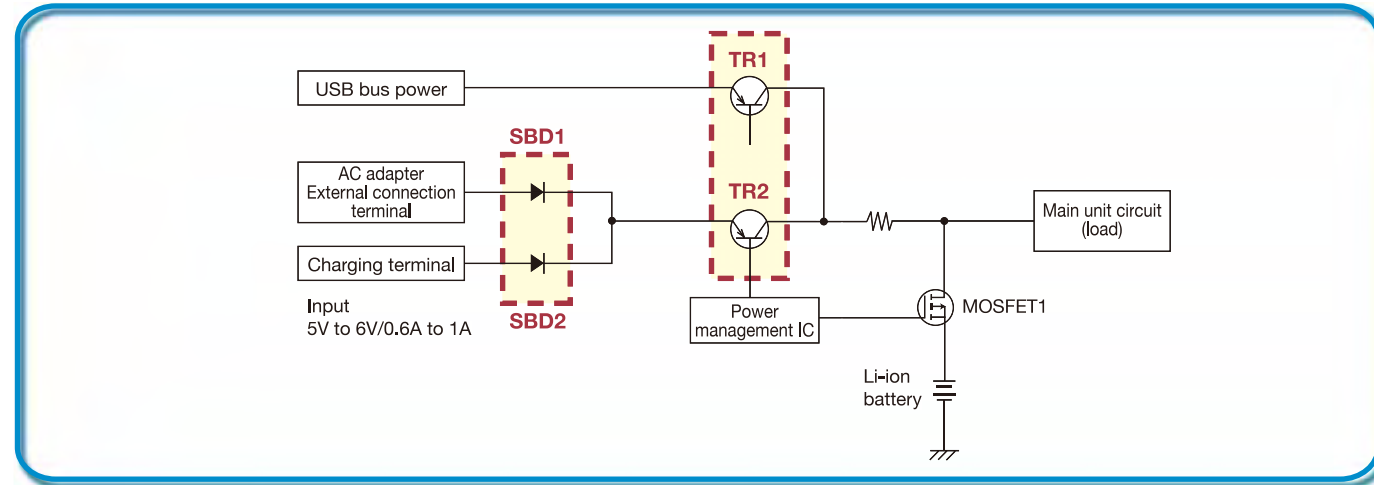

### Recommended Bipolar Transistors (PNP)

※: Development

V <sub>CEO</sub> [V]	I <sub>C</sub> [A]	MCPH3	MCPH6	CPH3	CPH6	VEC8	VEC8(2 in 1)
-12	2.5	MCH3143		CPH3143		※ VEC1105	
	3.0	MCH3106		CPH3121	CPH6121	※ VEC1104	
-15	6.0			CPH3107			
-30	2.0	MCH3144		CPH3144			
	3.0	MCH3109	※ MCH6122	CPH3122	CPH6122		VEC2102
	5.0			CPH3110		※ VEC1106	

### Recommended Schottky Barrier Diodes (Single)

#### [Features]

- Package size: 1.6×0.8mm and I<sub>O</sub>=1A, Minimum in industry size !
- Thickness of Package: Typ. 0.60mm

V <sub>R</sub> [V]	I <sub>O</sub> [A]	ECSP1008-2	ECSP1608-4
30	0.2		SS0203EJ SB0203EJ
		SS0503EC SB0503EC	SS0503EJ SB0503EJ
	1.0		SS1003EJ SB1003EJ

### Recommended Schottky Barrier Diodes (2 in 1: Parallel type)

#### [Features]

- Package size: 2.8×2.9mm and 30V/3A [SBS813/SBE813]
- Package size: 2.0×2.1mm and 30V/2A [SBS818], 15V/2A [SBS817]
- Thickness of Package: Typ. 0.75mm

※: Development

V <sub>R</sub> [V]	I <sub>O</sub> [A]	MCPH5	EMH8	CPH5	VEC8	
15	1.0	SBS808M SBE808		SBS804		
	2.0		SBS817 ※ SBE817			
30	0.5	SBS806M		SBE805		
	1.0	※ SBS810		SBE807	SBS814	
	2.0		SBS818 ※ SBE818			SBS811 SBE811
		3.0				SBS813 SBE813

## Li-ion Battery

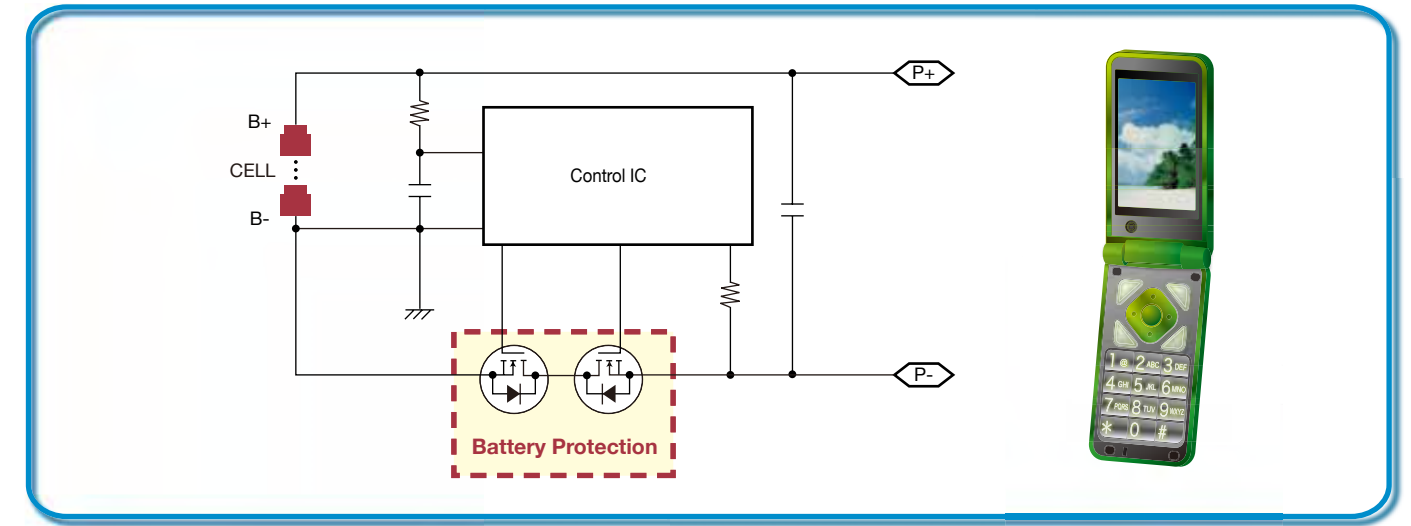

### Recommended MOSFETs (Nch)

V <sub>DSS</sub> [V]	EMH8	ECH8	TSSOP8	SOP8
20	EMH2405 EMH2407	ECH8601R ECH8649 ECH8651R	FTD2011A FTD2017R	FW231A FW232A
	EMH2402	ECH8622R	FTD2019A	

### Recommended MOSFETs for Machine Tools

V <sub>DSS</sub> [V]	Polarity	SMP	ZP	Drive
30	Nch		2SK4163	1.8V Drive
	Pch		TM1829Z	
45	Nch		2SK4164	4.0V Drive
	Pch		TM1831Z	
60	Nch	2SK4066	2SK4044	
	Pch		2SJ683	
75	Nch	2SK4065	2SK4165	
80	Pch		2SJ686	
100	Nch		2SK4045	
	Pch		2SJ684	



## DC-DC Converter/Load SW

### (1) DC-DC Converter

#### Recommended MOSFETs

Back Converter (Step Down)	Package	Type No.	VDSS [V]	RDS(on) max [mΩ] VGS=4V (*: VGS=4.5V)	Drive [V]	SBD		
	SCH6	SCH2809	-12	290*	1.8	15V/0.5A		
		SCH2810		530	2.5			
		SCH2811		830	4.0			
	MCPH5	MCH5815	-12	290*	1.8	4.0	15V/0.5A	
		MCH5818		530				
		MCH5802		1090				
		MCH5805		2300				
	CPH5	CPH5812	-12	290*	1.8	4.0	15V/2A	
		CPH5815		290*				
		CPH5818		490*				
		CPH5802		145				
		CPH5835		235				
		CPH5822		290				
VEC8	VEC2811	-30	168	4.0	4.0	30V/2A		
	VEC2817		-12	62*			2.5	15V/3A
Synchronous Back Converter (Pch + Nch or Nch + Nch)	Package	Type No.	VDSS [V]	RDS(on) max [mΩ] VGS=4V (*: VGS=4.5V)	Drive [V]	SBD		
	SCH6	SCH1305	-12	310*	1.8	-		
		SCH1406		20			210	
		SCH2806					440	
		SCH2816					4.0	
	MCPH3/5	MCH3317	-12	290*	1.8	4.0	-	
		MCH3456		15				160
		MCH5811		20				210
		MCH5819		30				520
	CPH3/5	CPH3321	-12	98*	1.8	4.0	-	
		CPH3313		-20	235			
		CPH3337		-30	77			
		CPH5809		30	90			
		CPH5819		30	520			
CPH5805		30		150				
Boost Converter (Step Up)	Package	Type No.	VDSS [V]	RDS(on) max [mΩ] VGS=4V	Drive [V]	SBD		
	SCH6	SCH2817	15	160	1.8	15V/0.5A		
		SCH2806		20			210	
		SCH2819		30			215	
		SCH2808		560			4.0	
	MCPH5	MCH5826	15	160	1.8	4.0	15V/0.5A	
		MCH5811		20	210			
		MCH5809		215	2.5			
		MCh5819		30	520			
	CPH5	CPH5803	20	210	1.8	4.0	15V/1A	
		CPH5811		63				
		CPH5831		63				
		CPH5809		90				
		CPH5819		150				
VEC8	VEC2813	20	66	1.8	4.0	30V/2A		
	VEC2816		30	99				

### [Bipolar Transistor Use Example]

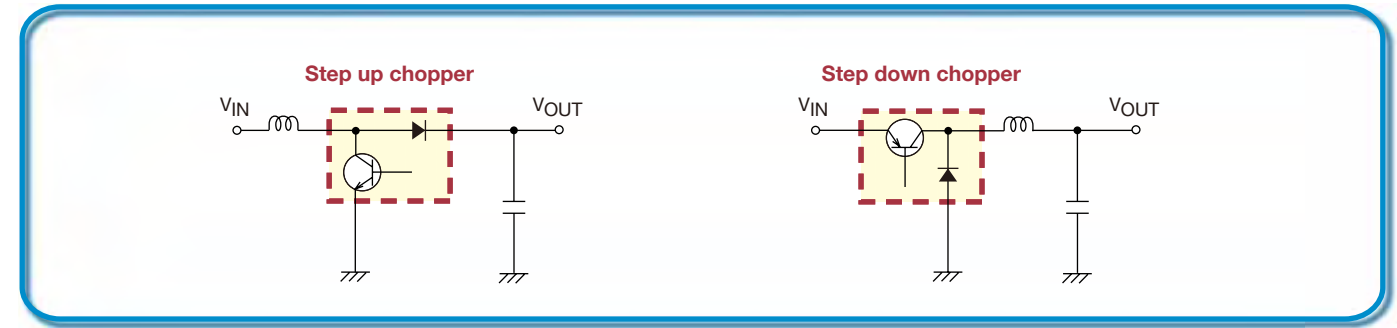

### Bipolar Transistors + Schottky Barrier Diodes

Type No.	Package	Absolute maximum ratings/Ta=25°C						Electrical characteristics/Ta=25°C										Internal chip equivalent product	Electrical connection			
		TR			SBD			TR				SBD										
		VCEO [V]	IC [A]	PC [W]	VRRM [V]	IO [A]	VCE [V]	IC [A]	min	max	IC [A]	IB [mA]	typ	max	VF [V]	IF [A]	max			VR [V]	max	IF [A]
CPH5706	CPH5	30	1.5	0.9	30	0.7	2	0.1	200	560	0.75	15	0.25	0.375	0.7	0.55	10	200	0.1	10	CPH3115 +SBS006	B18
CPH5705		30	3	0.9	15	1	2	0.5	200	560	1.5	30	0.155	0.23	0.5	0.35	6	500	0.1	15	CPH3109 +SBS004	B18
CPH5702		30	3	0.9	30	0.7	2	0.5	200	560	1.5	30	0.12	0.18	0.7	0.55	15	80	0.1	10	CPH3209 +SB07-03C	B22
CPH5703		50	3	0.9	50	0.5	2	0.1	200	560	1	50	0.08	0.12	0.5	0.55	25	50	0.1	10	CPH3205 +SB05-05CP	B22

### Bipolar Transistors (PNP)

Type No.	Package	Absolute maximum ratings/Ta=25°C			Electrical characteristics/Ta=25°C						Complementary product
		VCEO [V]	IC [A]	PC [W]	hFE		VCE (sat) [V]				
					min	max	IC [A]	IB [mA]	typ	max	
MCH3144	MCPH3	30	2	0.8 *1	200	560	1.5	75	0.17	0.26	MCH3244
MCH3109		30	3	0.8 *1	200	560	1.5	30	0.155	0.23	MCH3209
MCH3145		50	2	0.8 *1	200	560	1	50	0.165	0.33	MCH3245
MCH3105		50	3	0.8 *1	200	560	1	50	0.1	0.2	MCH3205

\*1: When mounted on ceramic substrate (600mm<sup>2</sup>×0.8mm)

### Bipolar Transistors (NPN)

Type No.	Package	Absolute maximum ratings/Ta=25°C			Electrical characteristics/Ta=25°C						Complementary product
		VCEO [V]	IC [A]	PC [W]	hFE		VCE (sat) [V]				
					min	max	IC [A]	IB [mA]	typ	max	
MCH3244	MCPH3	30	2	0.8 *1	200	560	1.5	75	0.16	0.24	MCH3144
MCH3221 *2		30	3	0.8 *1	250	400	1.5	30	0.08	0.12	-
MCH3245		50	2	0.8 *1	200	560	1	50	0.13	0.26	MCH3145
MCH3222 *2		50	3	0.8 *1	250	400	1	50	0.06	0.09	-

\*1: When mounted on ceramic substrate (600mm<sup>2</sup>×0.8mm) \*2: MBIT III series (New Product)

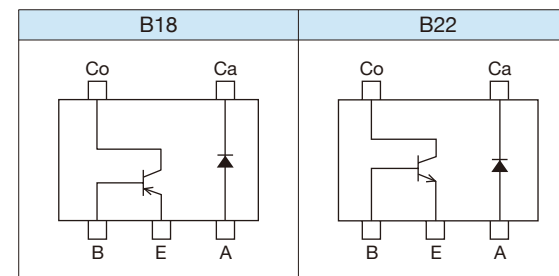

## (2) Load SW

### Recommended MOSFETs

V <sub>DSS</sub>	MCPH6	CPH6	VEC8	EMH8	Application Sample: Pch + Nch
20V	MCH6628	CPH6605	-	EMH2603	
30V	MCH6614	CPH6615	VEC2612	EMH2602	

### Power MOSFETs (Pch + Nch)

● New products

Type No.	Package	Polarity	Absolute maximum ratings/Ta=25°C				Electrical characteristics/Ta=25°C						Electrical connection
			V <sub>DSS</sub> [V]	V <sub>GSS</sub> [V]	I <sub>D</sub> [A]	P <sub>D</sub> [W]	R <sub>DS(on)</sub> [Ω]				C <sub>iss</sub> [pF]	Q <sub>g</sub> [nC]	
							V <sub>GS</sub> =10V		V <sub>GS</sub> =4(4.5)V				
● MCH6627	MCPH6	Pch	30	20	1	0.8	0.42	0.55	0.72	1	75	2.6	M11
		Nch	30	20	1.4	0.8	0.23	0.3	0.4	0.56	65	2.5	
● MCH6644		Pch	30	20	1.2	0.8	0.32	0.42	0.59	0.83	104	3.3	M11
		Nch	30	20	1.8	0.8	0.16	0.21	0.3	0.42	95	3.2	
● MCH6628		Pch	20	10	1	0.8	0.38	0.5	0.54	0.76	115	1.5	M11
		Nch	30	10	0.35	0.8	2.9	3.7	3.7	5.2	7	1.58	
MCH6613		Pch	30	10	0.2	0.8	8	10.4	11	15.4	7.5	1.43	M11
		Nch	30	10	0.35	0.8	2.9	3.7	3.7	5.2	7	1.58	
MCH6614		Pch	30	10	0.4	0.8	2.4	3.1	3.5	4.9	28	2	M11
		Nch	30	10	0.35	0.8	2.9	3.7	3.7	5.2	7	1.58	
MCH6615		Pch	30	10	0.4	0.8	2.4	3.1	3.5	4.9	28	2	M11
		Nch	30	10	0.65	0.8	0.9	1.2	1.2	1.7	30	2.34	
MCH6634		Pch	30	10	0.4	0.8	1.5	1.9	2	2.8	40	0.83	M11
		Nch	30	10	0.7	0.8	0.7	0.9	0.8	1.15	30	1	
● CPH6614	Pch	30	20	1.2	0.8	0.32	0.42	0.59	0.83	104	3.3	M12	
	Nch	30	20	1.8	0.8	0.15	0.195	0.29	0.41	95	3.2		
● CPH6615	Pch	30	20	1.8	0.9	0.18	0.235	0.32	0.45	226	5.5	M12	
	Nch	30	20	2.5	0.9	0.079	0.105	0.15	0.21	187	5.2		
CPH6605	Pch	20	10	1.5	0.8	0.18	0.235	0.24	0.34	40	3.2	M07	
	Nch	30	10	0.65	0.8	0.9	1.2	1.2	1.7	30	2.34		
CPH6610	Pch	30	9	0.4	0.8	1.4	1.8	2	2.8	40	0.83	M07	
	Nch	30	20	1.4	0.8	0.245	0.32	0.415	0.58	65	2.5		
● VEC2602	Pch	30	20	3	0.9	0.065	0.086	0.117	0.168	510	11	M13	
	Nch	30	20	4	0.9	0.037	0.048	0.07	0.099	370	8.5		
● VEC2612	Pch	30	20	3	0.9	0.073	0.095	0.115	0.161	180	4.9	M13	
	Nch	30	20	3	0.9	0.065	0.086	0.117	0.168	510	11		
● EMH2602	Pch	30	20	2	1	0.053	0.069	0.105	0.15	280	6.4	M13	
	Nch	30	20	3.5	1	0.115	0.15	0.215	0.31	285	6.7		
● EMH2603	Pch	20	10	2	1.1	0.165	0.235	0.26	0.52	420	5	M30	
	Nch	30	10	0.15	0.6	3.7	5.2	6.4	12.8	7	2		
SCH2602	Pch	12	10	1.5	0.6	-	-	0.235	0.31	160	2.6	M26	
	Nch	30	10	0.35	0.6	-	-	2.9	3.7	7	1.58		

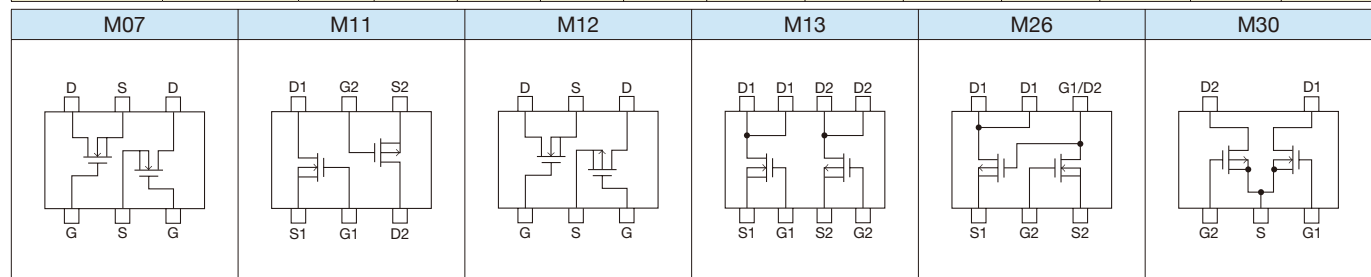

## LCD-Backlight

### [Power MOSFET Use Example]

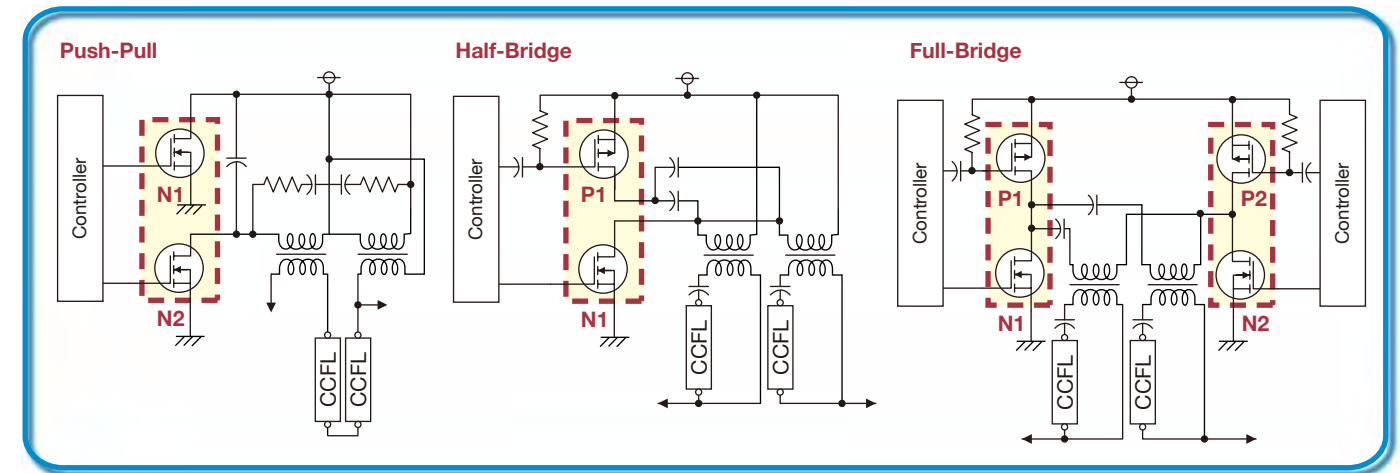

### Power MOSFETs

Type No.	Package	Polarity	V <sub>DSS</sub> [V]	R <sub>DS(on)</sub> max [mΩ] (V <sub>GS</sub> =4V)	V <sub>IN</sub> [V]	Set size [inch]	Use example
VEC2402	VEC8	Nch+Nch	30	99	5 to 12	Small Screen 2.5 to 8	Push-Pull
ECH8606	ECH8	Nch+Nch	30	75			
ECH8402		Nch	30	32			
VEC2602	VEC8	Pch	30	168			Half-Bridge Full-Bridge
		Nch	30	99			
VEC2612		Pch	30	168			
		Nch	30	161			
ECH8609	ECH8	Pch	30	120			
		Nch	30	75			
		ECH8402	Nch	30			
ECH8302			Pch	30	48		

### [Bipolar Transistor Use Example]

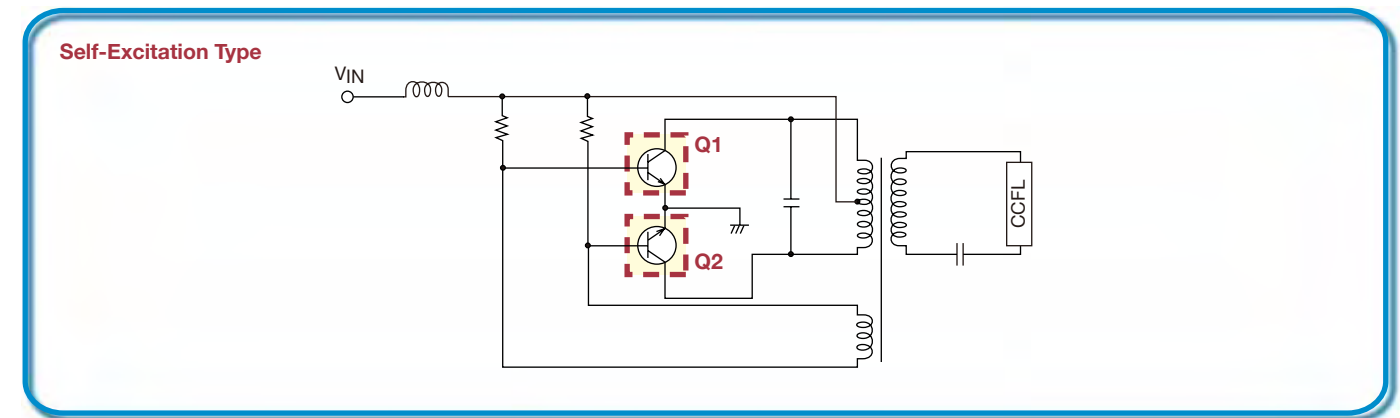

### Bipolar Transistors

Type No.	Package	Polarity	V <sub>CE(S)</sub> (*V <sub>CB0</sub> ) [V]	I <sub>C</sub> [A]	V <sub>IN</sub> [V]	Set size [inch]	Use example
CPH5503	CPH5	NPN+NPN	40*	3	5 to 12	Small Screen 2.5 to 8	Self-Excitation Type
CPH5504		NPN+NPN	80	3			

## Flash Unit

[Use Example]

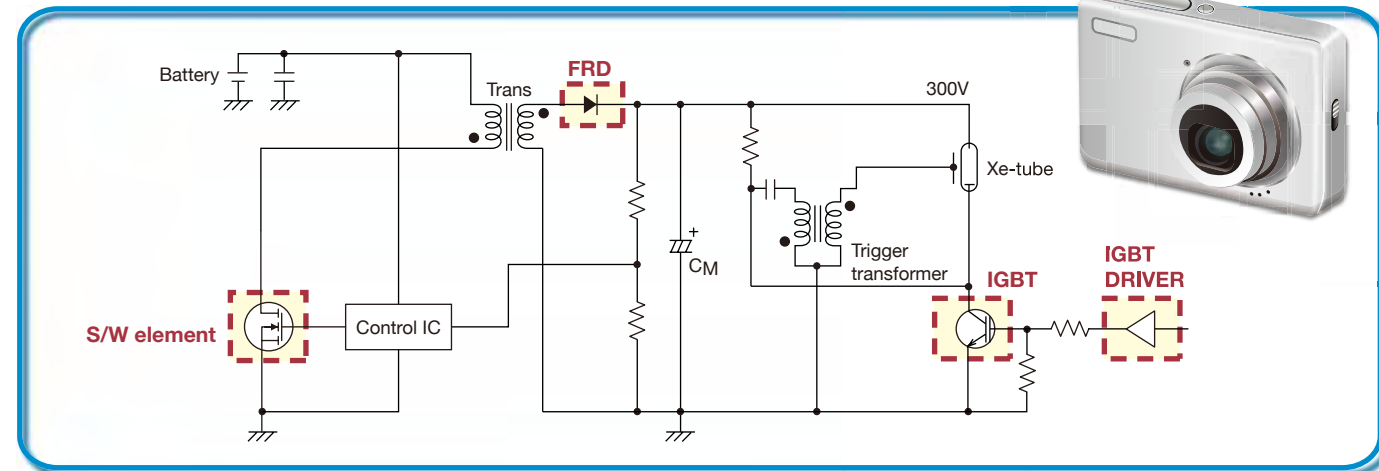

### Bipolar Transistors (NPN)

Type No.	Package	Polarity	Absolute maximum ratings/Ta=25°C			Electrical characteristics/Ta=25°C					
			V <sub>CEO</sub> [V]	I <sub>C</sub> [A]	P <sub>C</sub> [W]	hFE		V <sub>CE</sub> (sat) [V]			
						min	max	I <sub>C</sub> [A]	I <sub>B</sub> [mA]	typ	max
CPH3223	CPH	NPN	50	3	0.9	200	560	1	50	0.09	0.13
CPH3236		NPN	50	3	0.9	250	400	1	50	0.06	0.1

### MOSFETs (Nch)

● New products

Type No.	Package	Polarity	Absolute maximum ratings/Ta=25°C				Electrical characteristics/Ta=25°C							
			V <sub>DSS</sub> [V]	V <sub>GSS</sub> [V]	I <sub>D</sub> [A]	P <sub>D</sub> [W]	R <sub>DS</sub> (on) [Ω]				C <sub>iss</sub> [pF]	Q <sub>g</sub> [nC]		
							V <sub>G</sub> S=10V		V <sub>G</sub> S=4V				V <sub>G</sub> S=2.5V	
● MCH6422	MCPH6	Nch	60	10	2	1.5	-	-	0.17	0.22	0.19	0.27	325	4.2
MCH6424		Nch	60	10	3	1.5	-	-	0.085	0.115	0.095	0.135	690	8.2
● MCH6423		Nch	60	20	2	1.5	0.17	0.22	0.21	0.3	-	-	220	6.4

### Bipolar Transistors (NPN) + MOSFETs (Nch)

Type No.	Package	Absolute maximum ratings/Ta=25°C							Electrical characteristics/Ta=25°C												
		TR			MOSFET				hFE		V <sub>CE</sub> (sat) [V]				R <sub>DS</sub> (on) [Ω]				C <sub>iss</sub> [pF]	Q <sub>g</sub> [nC]	
		V <sub>CEO</sub> [V]	I <sub>C</sub> [A]	P <sub>C</sub> [W]	V <sub>DSS</sub> [V]	V <sub>GSS</sub> [V]	I <sub>D</sub> [A]	P <sub>D</sub> [W]	min	max	Cob [pF]	I <sub>C</sub> [A]	I <sub>B</sub> [mA]	typ	max	V <sub>G</sub> S=4V	V <sub>G</sub> S=2.5V				
VEC2901	VEC8	50	5	1.1	30	10	0.15	0.25	250	400	26	1.6	53	0.055	0.11	2.9	3.7	3.7	5.2	7	1.58

### IGBT Drivers

Type No.	Package	V <sub>DD</sub> [V]	V <sub>IN</sub> / V <sub>OUT</sub> [V]	P <sub>D</sub> [W]	V <sub>IH</sub> min [V]	V <sub>IL</sub> max [V]	I <sub>O</sub> +I <sub>O</sub> -typ [mA]			
							V <sub>DD</sub> =5V		V <sub>DD</sub> =2.5V	
							CL [pF]	CL [pF]	CL [pF]	CL [pF]
TND721MH5	MCPH5	-0.3 to 7.5	-0.3 to V <sub>DD</sub> +0.3	0.8	2	1	5000	50	5000	10

### Flash Circuit IGBTs

● New products

Type No.	Package	Polarity	Absolute maximum ratings/Ta=25°C			Electrical characteristics/Ta=25°C										
			V <sub>CES</sub> [V]	V <sub>GES</sub> (DC) [V]	I <sub>CP</sub> [A]	V <sub>GE</sub> (off) [V]				V <sub>CE</sub> (sat) [V]				C <sub>ies</sub>		
						V <sub>CE</sub> [V]	I <sub>C</sub> [mA]	min	max	I <sub>C</sub> [A]	V <sub>GE</sub> [V]	min	max	V <sub>CE</sub> [V]	f [MHz]	typ
● TIG030TS	TSSOP8	Nch	400	±6	150	10	1	0.5	1.2	150	4	3.7	5.4	10	1	2610
● TIG032TS		Nch	400	±6	180	10	1	0.4	1	150	2.5	3.4	4.8	10	1	5100

### FRD

Type No.	Package	V <sub>R</sub> [V]	I <sub>O</sub> [mA]	V <sub>F</sub> I <sub>F</sub> =0.1A [V]	I <sub>R</sub> V <sub>R</sub> =400V [μA]	t <sub>rr</sub> max I <sub>F</sub> =I <sub>R</sub> =100mA, See specified test circuit [ns]
RE0208DA	SOD-323	800	200	4.0	3	55

## Condenser Microphone

[High-Frequency Devices Use Example]

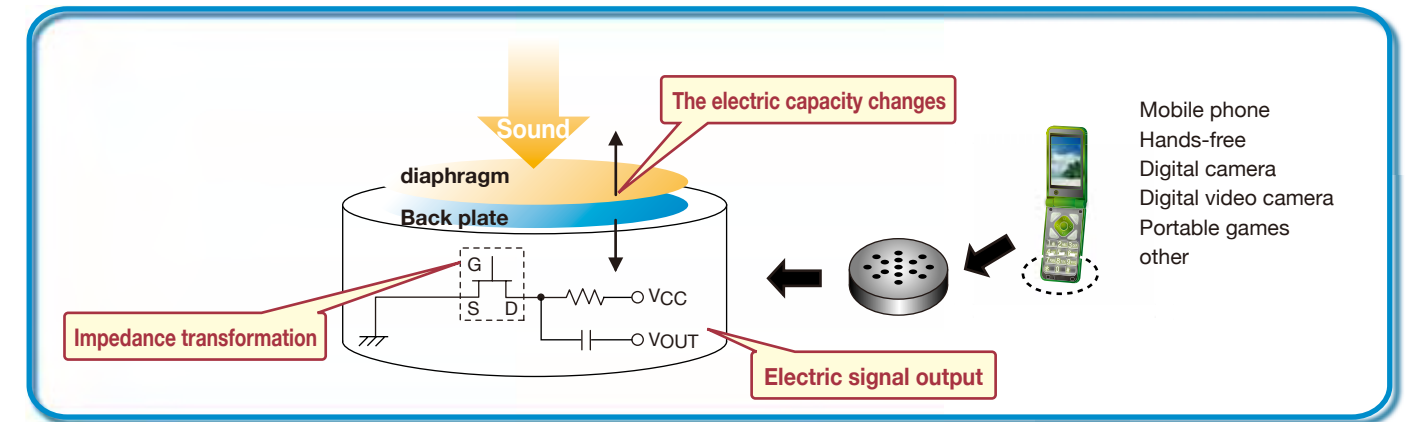

### High-Frequency Devices for Condenser Microphone

Type No.	Package	Absolute maximum ratings/Ta=25°C			Electrical characteristics/Ta=25°C							
		V <sub>GDS</sub> V <sub>GDO</sub> [V]	I <sub>D</sub> [mA]	P <sub>D</sub> [mW]	I <sub>DSS</sub> [mA]		y <sub>fs</sub>   typ(*min) [mS]	C <sub>iss</sub> typ [pF]	C <sub>rss</sub> typ [pF]	G <sub>v</sub> typ [dB]	V <sub>NO</sub> max [dB]	
					min	max						
TF246	USFP	20	1	30	0.14	0.35	1.0	3.5	0.65	-3.0	-110	
TF252		20	1	30	0.14	0.35	1.4	3.1	0.95	1.0	-102	
TF202C	TSSFP	20	1	100	0.14	0.35	1.0	3.5	0.65	-3.0	-110	
TF222B		20	1	100	0.14	0.35	1.4	5.0	1.1	-2.0	-102	
TF218THC	VTFP	20	1	100	0.14	0.35	1.0	3.5	0.65	-3.0	-110	
TF208TH		20	1	100	0.14	0.35	1.4	5.0	1.1	-2.0	-102	
TF252TH		20	1	100	0.14	0.35	1.4	3.1	0.95	1.0	-102	

Type No.	Package (unit: mm)	Absolute maximum ratings/Ta=25°C			Electrical characteristics/Ta=25°C						
		V <sub>IN</sub> [V]	V <sub>DD</sub> [V]	P <sub>D</sub> [mW]	V <sub>DD</sub> [V]		C <sub>i</sub> typ [pF]	I <sub>DD</sub> [μA]		G <sub>v</sub> [dB]	V <sub>NO</sub> [dB]
EC4K11KF	ECSP1410 (1.4×1.0×0.4)	±0.5	4	100	2	3.6	2.7	140	100	12	-90
EC4K14MF	ECSP1410 (1.4×1.0×0.32)	±0.5	4	100	2	3.6	2.7	140	200	12	-90

## USB (3.3V) Signal Line Protection Devices

[Use Example]

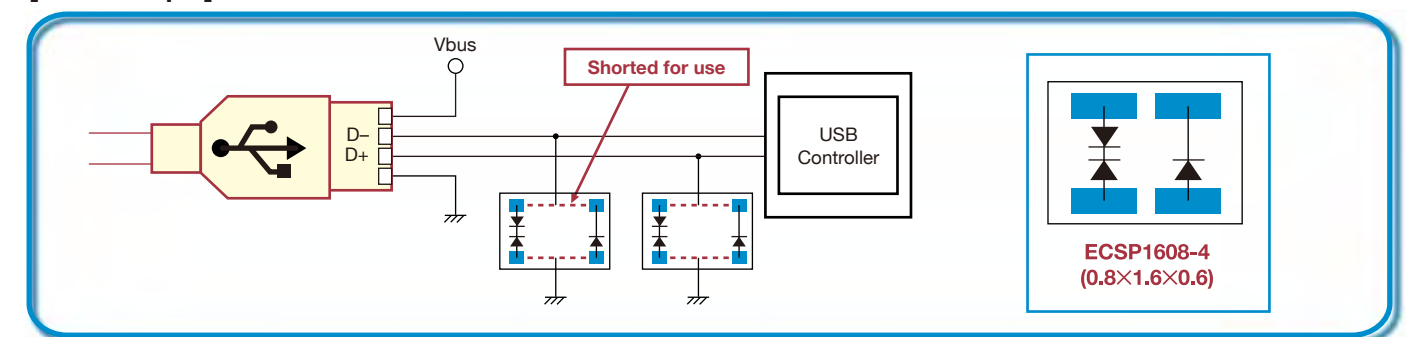

### Recommended Device

Type No.	Package	V <sub>R</sub> [V]		V <sub>F</sub> [V] I <sub>F</sub> =1mA	I <sub>L</sub> [μA] V <sub>R</sub> =2.5V	C <sub>T</sub> [pF] f=1MHz/ V <sub>R</sub> =0V typ
		I <sub>R</sub> =1μA min	I <sub>R</sub> =1mA max			
VS002E4	ECSP1608-4	3.4	4.0	0.35	1	16

### Noise clamping of USB eye patterns

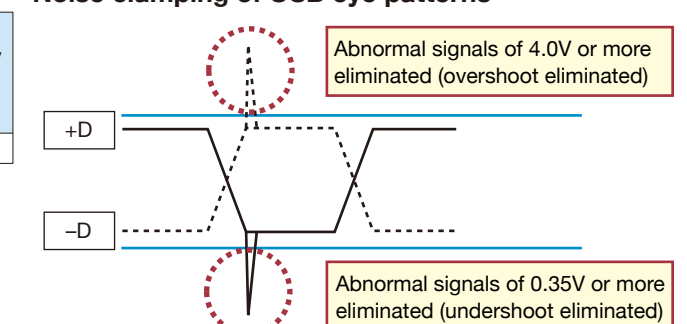



## Devices for Motor

[MOSFETs Use Example]

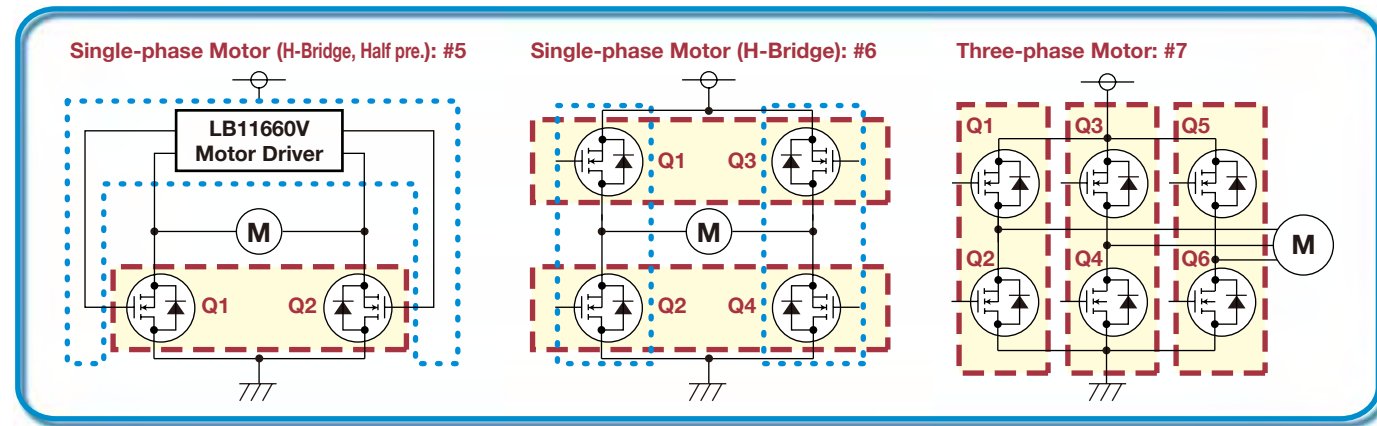

### MOSFETs

Type No.	Package	Polarity	Absolute maximum ratings/Ta=25°C				Electrical characteristics/Ta=25°C						Use example
			VDSS [V]	VGSS [V]	ID [A]	PD [W]	RDS (on) [Ω]				Ciss [pF]	Qg [nC]	
							VGS=10(15)V		VGS=4(4.5)V				
MCH3410	MCPH3	Nch	30	20	2	0.9	0.115	0.15	0.19	0.27	120	3.6	#5
MCH3421		Nch	100	20	0.8	0.9	0.68	0.89	0.85	1.2	165	4.8	
MCH6423	MCPH6	Nch	60	20	2	1.5	0.17	0.22	0.21	0.3	220	6.4	
CPH3418	CPH3	Nch	30	20	1.4	0.9	0.23	0.3	0.4	0.56	65	2.5	
CPH3424		Nch	60	20	1.8	1	0.17	0.22	0.21	0.3	220	6.4	
CPH3427		Nch	100	20	1	1	0.48	0.63	0.58	0.81	240	6.5	
VEC2402	VEC8	Nch+Nch	30	20	4	0.9	0.037	0.048	0.07	0.099	370	8.5	
CPH6616	CPH6	Nch+Nch	30	20	2.5	0.9	0.079	0.105	0.15	0.21	187	5.2	

### MOSFETs (Pch+Nch)

Type No.	Package	Polarity	Absolute maximum ratings/Ta=25°C				Electrical characteristics/Ta=25°C						Use example
			VDSS [V]	VGSS [V]	ID [A]	PD [W]	RDS (on) [Ω]				Ciss [pF]	Qg [nC]	
							VGS=10V		VGS=4(4.5)V				
VEC2602	VEC8	Pch	30	20	3	0.9	0.065	0.086	0.117	0.168	510	11	#6
		Nch	30	20	4	0.9	0.037	0.048	0.07	0.099	370	8.5	
ECH8609	ECH8	Pch	30	20	4	1.3	0.05	0.067	0.087	0.12	550	2.2	#6, #7
		Nch	30	20	6	1.3	0.025	0.034	0.052	0.075	510	11	
FW340		Pch	30	20	5	1.8	0.041	0.053	0.07	0.098	1000	16.5	#6, #7
		Nch	30	20	5	1.8	0.037	0.048	0.064	0.09	460	8.6	
FW377		Pch	35	20	5	1.8	0.037	0.049	0.062	0.087	1224	24	#6, #7
		Nch	35	20	6	1.8	0.025	0.033	0.043	0.061	1050	20	
FW356	SOP8	Pch	60	20	3.5	2	0.11	0.145	0.15	0.21	990	22	#7
		Nch	60	20	5	2	0.043	0.058	0.056	0.084	790	16	
FW359		Pch	60	20	3	1.8	0.11	0.145	0.145	0.205	990	22	#6
		Nch	60	20	3	1.8	0.11	0.145	0.15	0.215	300	7.8	
FW360		Pch	100	20	2	1.4	0.24	0.315	0.32	0.45	935	20	#6, #7
		Nch	100	20	2	1.4	0.175	0.22	0.22	0.31	530	13	

### MOSFETs

Type No.	Package	Polarity	Absolute maximum ratings/Ta=25°C				Electrical characteristics/Ta=25°C						Use example
			VDSS [V]	VGSS [V]	ID [A]	PD [W]	RDS (on) [Ω]				Ciss [pF]	Qg [nC]	
							VGS=10(15)V		VGS=4(4.5)V				
2SJ646	TP	Pch	30	20	8	15	0.058	0.075	0.097	0.136	510	11	#6, #7
2SJ634		Pch	60	20	8	20	0.105	0.138	0.145	0.205	990	22	#7
2SJ637		Pch	100	20	5	20	0.24	0.312	0.32	0.45	935	20	#6, #7
2SK4067	TP	Nch	30	20	8	10	0.085	0.115	0.155	0.22	260	6	#6, #7
2SK3492		Nch	60	20	8	15	0.115	0.15	0.155	0.22	300	7.8	#7
2SK3617		Nch	100	20	6	15	0.18	0.225	0.225	0.315	530	13	#7

## Devices for Fan Motor

[Bipolar Transistor Use Example]

- For the purpose of power consumption reduction, low saturated voltage transistor is recommended.
- PCP and TP packages with good radiation are recommended.
- Composite type (B-E bias resistor, and C-E diode are embedded) is recommended for miniaturization purpose.

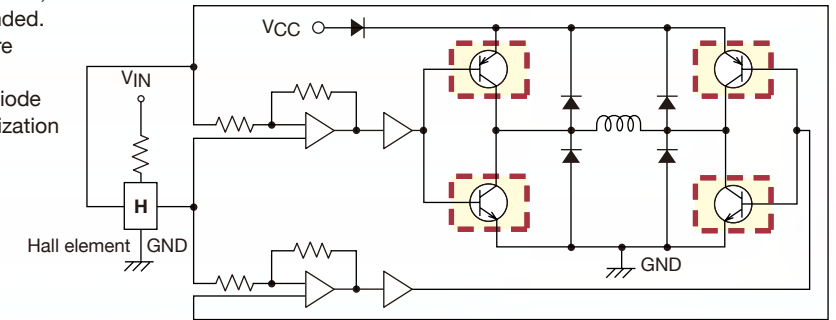

### Bipolar Transistors

Type No.	Package	Polarity	Absolute maximum ratings/Ta=25°C			Electrical characteristics/Ta=25°C						Complementary product
			VCEO [V]	IC [A]	PC [W]	hFE		VCE (sat) [V]				
						min	max	IC [A]	IB [mA]	typ	max	
● 2SA2124	PCP	PNP	30	2	1.3 <sup>*2</sup>	200	560	1.5	75	0.2	0.4	2SC6044
2SA2012		PNP	30	5	1.3 <sup>*3</sup>	200	560	1.5	30	0.14	0.21	2SC5565
● 2SA2125		PNP	50	3	1.3 <sup>*3</sup>	200	560	1	50	0.125	0.23	2SC5964
2SA2013		PNP	50	4	1.3 <sup>*3</sup>	200	560	1	50	0.105	0.18	2SC5566
2SA1416		PNP	100	1	1.3 <sup>*3</sup>	100	400	0.4	40	0.2	0.6	2SC3646
2SA1417		PNP	100	2	1.5 <sup>*3</sup>	100	400	1	100	0.22	0.6	2SC3647
● 2SA2126		PNP	50	3	15 <sup>*1</sup>	200	560	1	50	0.135	0.27	-
2SA2039		PNP	50	5	15 <sup>*1</sup>	200	560	1	50	0.115	0.195	2SC5706
2SA2040		PNP	50	8	15 <sup>*1</sup>	200	560	3.5	175	0.23	0.39	2SC5707
● 2SA2169		PNP	50	10	20 <sup>*1</sup>	200	560	5	250	0.29	0.58	2SC6017
2SA1592	PNP	PNP	100	1	10 <sup>*1</sup>	100	400	0.4	40	0.2	0.6	2SC4134
2SA1593		PNP	100	2	15 <sup>*1</sup>	100	400	1	100	0.22	0.6	2SC4135
2SA1552		PNP	160	1.5	1	100	400	0.5	50	0.2	0.5	2SC4027
● 2SC6044		NPN	30	2	1.3 <sup>*2</sup>	200	560	1.5	75	0.17	0.26	2SA2124
2SC5565		NPN	30	5	1.3 <sup>*3</sup>	200	560	1.5	30	0.125	0.19	2SA2012
● 2SC5964		NPN	50	3	1.3 <sup>*3</sup>	200	560	1	50	0.1	0.15	2SA2125
2SC5566		NPN	50	4	1.3 <sup>*3</sup>	200	560	1	50	0.085	0.13	2SA2013
2SC3646		NPN	100	1	1.3 <sup>*3</sup>	100	400	0.4	40	0.1	0.4	2SA1416
2SC3647		NPN	100	2	1.5 <sup>*3</sup>	100	400	1	100	0.13	0.4	2SA1417
2SC5706		NPN	50	5	15 <sup>*1</sup>	200	560	1	50	0.09	0.135	2SA2039
2SC5707	TP	NPN	50	8	15 <sup>*1</sup>	200	560	3.5	175	0.16	0.24	2SA2040
● 2SC6017		NPN	50	10	20 <sup>*1</sup>	200	700	5	250	0.18	0.36	2SA2169
2SC4134		NPN	100	1	10 <sup>*1</sup>	100	400	0.4	40	0.1	0.4	2SA1592
2SC4135		NPN	100	2	15 <sup>*1</sup>	100	400	1	100	0.13	0.4	2SA1593
2SC4027		NPN	160	1.5	1	100	400	0.5	50	0.13	0.45	2SA1552

\*1: Tc=25°C \*2: When mounted on ceramic substrate (450mm<sup>2</sup>×0.8mm) \*3: When mounted on ceramic substrate (250mm<sup>2</sup>×0.8mm)

### Bipolar Transistors: Built-in Damper Diode

Type No.	Package	Polarity	Absolute maximum ratings/Ta=25°C			Electrical characteristics/Ta=25°C						
			VCEO [V]	IC [A]	PC [W]	hFE min	VCE (sat) [V]			VF IF=0.5A [V]	RBE (kΩ)	
							IC [A]	IB [mA]	typ			max
2SB1397	PNP	PNP	20	2	1.3 <sup>*3</sup>	70	1	50	0.25	0.5	1.5	1.6
2SB1325		PNP	20	4	1.5 <sup>*3</sup>	70	3	150	0.25	0.5	1.5	1.5
2SB1324		PNP	30	3	1.5 <sup>*3</sup>	70	2	100	0.25	0.6	1.5	0.8
● 2SB1739	TP	PNP	30	3	1.5 <sup>*3</sup>	70	2	100	0.28	0.6	1.5	0.8
2SD2100	PNP	NPN	20	2	1.3 <sup>*3</sup>	70	1	50	0.25	0.5	1.5	1.6
2SD1999		NPN	20	4	1.5 <sup>*3</sup>	70	3	150	0.25	0.5	1.5	1.5
2SD1998		NPN	30	3	1.5 <sup>*3</sup>	70	2	100	0.2	0.5	1.5	0.8
● 2SD2720		TP	NPN	30	3	1.5 <sup>*3</sup>	70	2	100	0.23	0.5	1.5

\*1: Tc=25°C \*2: When mounted on ceramic substrate (450mm<sup>2</sup>×0.8mm) \*3: When mounted on ceramic substrate (250mm<sup>2</sup>×0.8mm)



## Switching Power Supply Types & Recommended Power MOSFETs Map

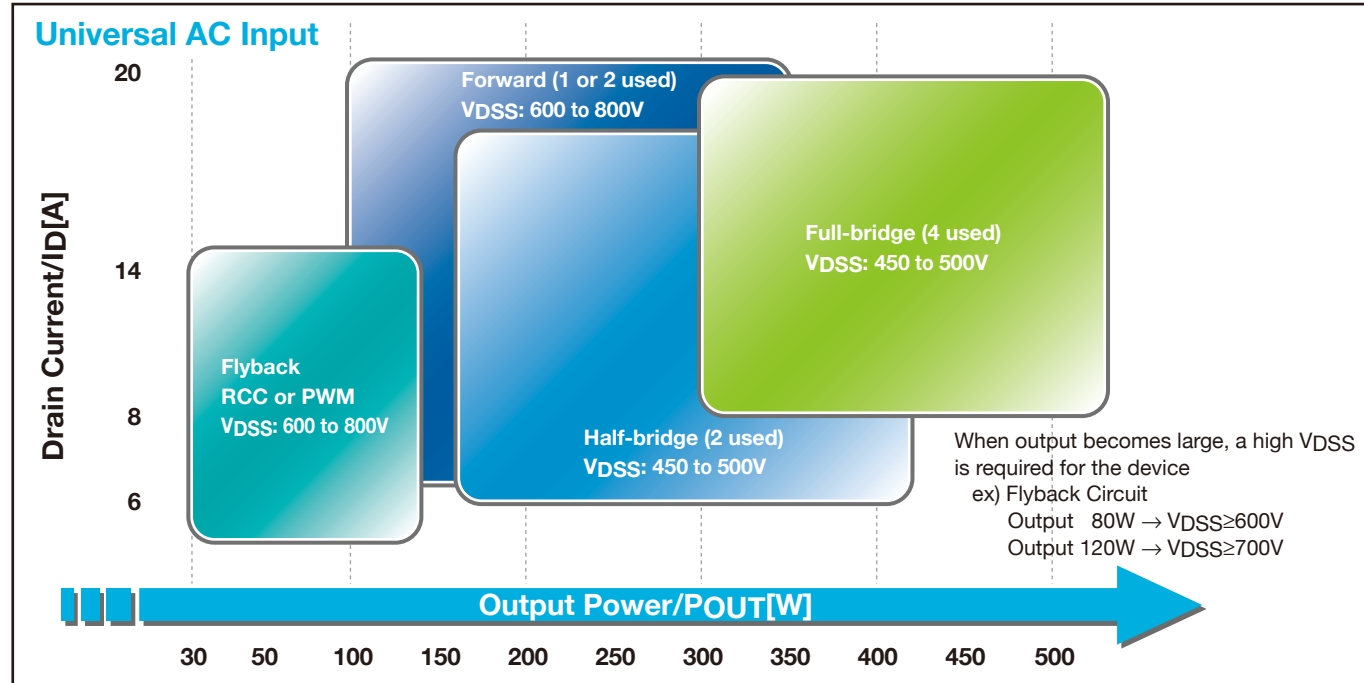

## Application Example

**(1) Flyback**  
For low-output use (up to 150W)  
few externally-connected parts required  
1 MOSFET is used for switching

**(2) Forward**  
Usable for middle-large output (100 to 300W)  
Several switching MOSFETs can be used in parallel  
Several switching MOSFETs can be used

**(3) Half-Bridge**  
For middle output (<150 to 400W)  
MOSFET with a lower voltage than flyback or forward voltage can be used  
2 switching MOSFETs are used

**(4) Full-Bridge**  
For high output (>300 to 400W)  
MOSFET with a lower voltage than flyback or forward voltage can be used  
4 switching MOSFETs are used

## Switching Devices

[MOSFET/FRD/SBD Use Example]

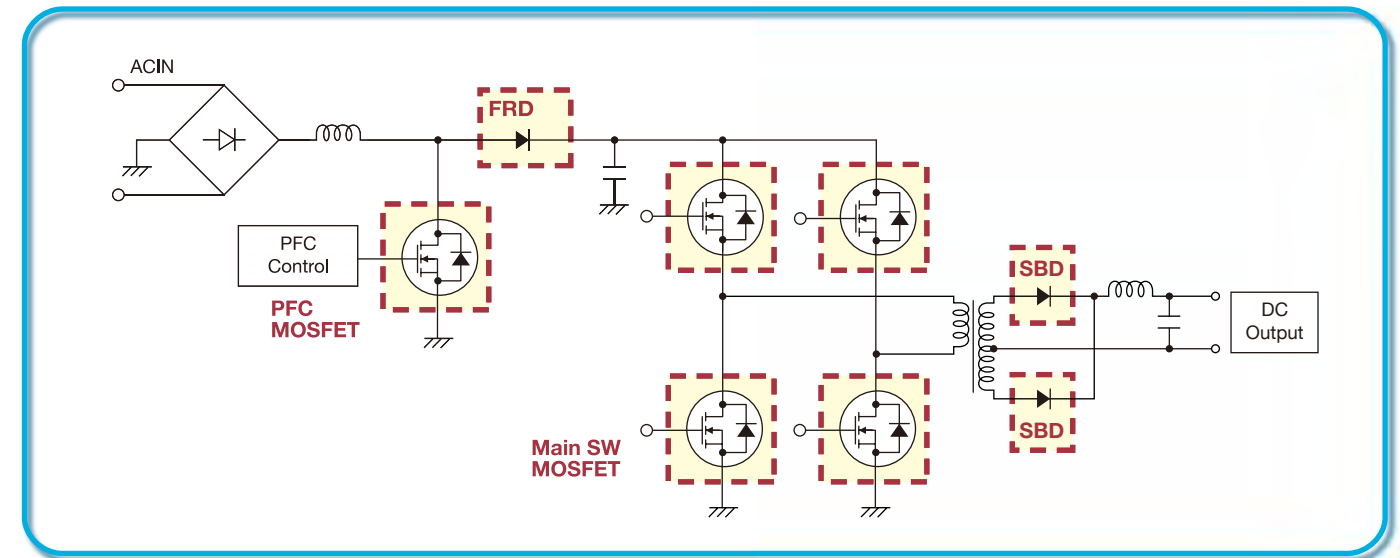

### (1) Power MOSFET/SBD/FRD for Adapter

Recommended Devices

Applications/Power	Set Spec		PFC	Main SW	Rectifier
	V <sub>OUT</sub> [V]	I <sub>OUT</sub> [A]	MOSFET	MOSFET	SBD
Game machine 50W	5	2.0 to 4.0	-	2SK4086LS (600V/0.58Ω)	SBT80-04J
	12	1.0 to 2.0			SBT100-16JS
Notebook PC 65W	20	2.0 to 4.0	-	2SK4087LS (600V/0.47Ω)	SBT100-16JS
General-purpose 75 to 90W	5	2.0 to 4.0	2SK4085LS 500V/0.33Ω	2SK4087LS (600V/0.47Ω)	SBT80-04J
	12	3.0 to 5.0			SBT150-10JS
	24				SBT100-16JS

### (2) Power MOSFET/SBD/FRD for other power supply

Recommended Devices [Other sets]

Set	Set Specification		PFC		Main SW	Rectifier
	Specification	Power [W]	FRD	MOSFET	MOSFET	SBD
Printer	Domestic (Japan)	50	-	-	2SK4096LS	SBT150-10JS
	W/W	50	-	-	2SK4098LS	SBT150-10JS
BL DVD recorder	Domestic (Japan)	100	* RD0506LS	2SK4097LS	2SK4087LS	SBT100-16JS
DVD recorder	Domestic (Japan)	60	-	-	2SK4097LS	SBT80-06J
Desktop PC	W/W	>200	* RD1006LS	2SK4085LS	2SK4125	SBT350-04J
PDP TV	W/W	>300	* RD1006LS	2SK4124	2SK4124	SBT100-16JS

#: Development

## (3) Bipolar Transistors for Adapter

### [Bipolar Transistor Use Example]

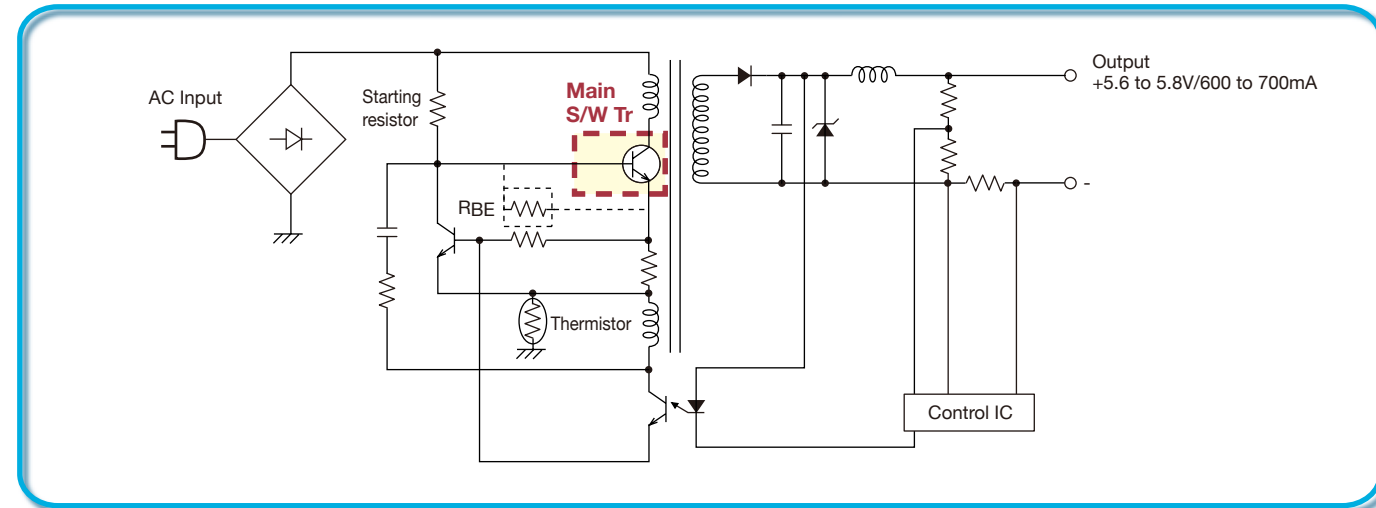

### Bipolar Transistors [VCBO=700V/800V Series (AC Adapter)]

Type No.	Package	Absolute maximum ratings/Ta=25°C			Electrical characteristics/Ta=25°C							Input Voltage [V]	AC Adapter Circuits [W]
		VCBO [V]	VCEO [V]	IC [A]	hFE		VCE (sat) [V]						
					IC [A]	min	max	IC [mA]	IB [mA]	max			
2SC5823	TP	700	400	1.5	0.1	20	50	700	140	0.8	100/220	3/6	
2SC5808	TP	700	400	2.5	0.3	20	50	1200	240	0.8	100/220	4/8	
* TT2240NMP	NMP	700	400	1.0	0.1	15	30	500	100	0.8	100/220	1.5/3	
2SC6065-V	NMP	700	400	1.5	0.1	20	50	700	140	0.8	100/220	3/6	
2SC6083	SPA	700	350	1.0	0.1	100	200	500	100	0.8	100	1.5	
2SC6083A	SPA	700	400	1.0	0.1	50	100	500	100	0.8	100/220	1.5/3	
* 2SC6146	SPA	800	350	1.0	0.1	100	200	500	100	0.8	220	3	
CPH3249	CPH3	700	350	1.0	0.1	100	200	500	100	0.8	100/220	1.5/3	
CPH3249A	CPH3	700	400	1.0	0.1	50	100	500	100	0.8	100/220	1.5/3	

\*: Development

## ■ LCD TV

### Recommended Devices by LCD-TV Panel Size

#### (1) When BL inverter is half-bridge circuit, and AV output is flyback circuit

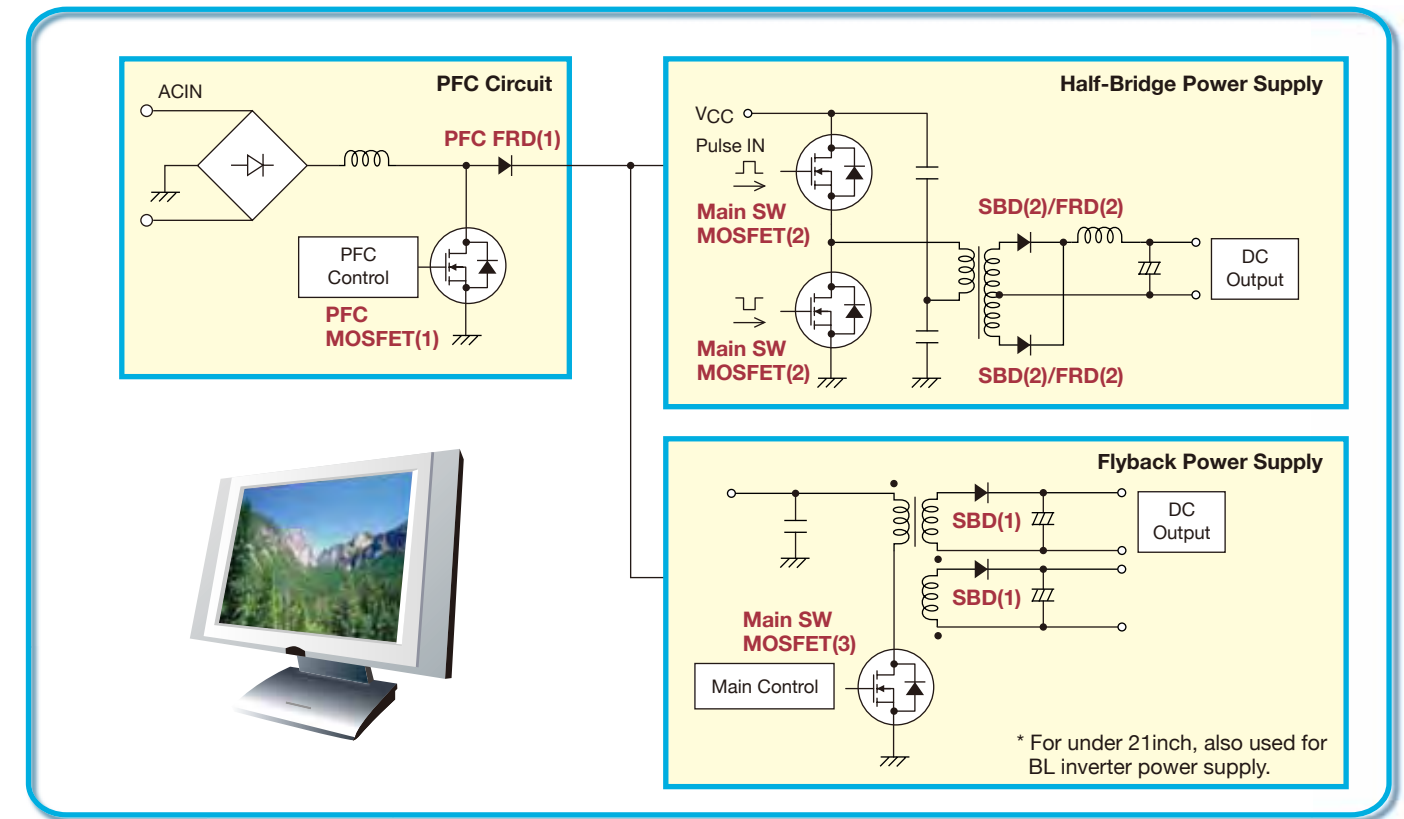

### ◆ Lineup

Set Spec			PFC		SPS for AV Processor	SPS for BL Inverter	2nd Rectifier
Panel Size [inch]	POUT [W]	VOUT [V]	FRD(1)	MOSFET(1)	MOSFET(2)	MOSFET(3)	SBD(1) SBD(2)/FRD(2)
up to 21	70	5/12	-	-	2SK4086LS (also used for BL power supply)	-	SBT80-06J(1) SBT100-16JS(1)
26 to 32	150	5 to 12 24	* RD1006LS	2SK4085LS	2SK4098LS	2SK4096LS×2	SBT100-16JS(1) SBT100-16JS(2)
37 to 42	250	5 to 12 24	* RD0506LS	2SK4124×2	2SK4098LS	2SK4097LS×2	SBT100-16JS(1) SBT150-10JS(2)
at least 42	350	5 to 12 24/60	* RD1006LS	2SK4124×3	2SK4101LS	2SK4084LS×2	SBT100-16JS(2) SBT150-10JS(1) RD2004LS(2)

\*: Development

#### [Power supply block]

##### • Circuit

For under 21inch, used for both AV processor (main power supply) and BL inverter power supply.

For larger than 26inch, 2-power supply system is usually used (one is for BL inverter use, and the other is for AV processor use).

##### • Secondary-side diode voltage

In case of flyback circuit, diode voltage should be 100V and above for 12V output (when PFC output is 380V).

In case of half-bridge circuit, diode voltage should be 100V and above for 24V output (when PFC output is 380V).



## (2) The example when BL inverter adopts PFC voltage direct input circuit, and AV output adopts flyback circuit

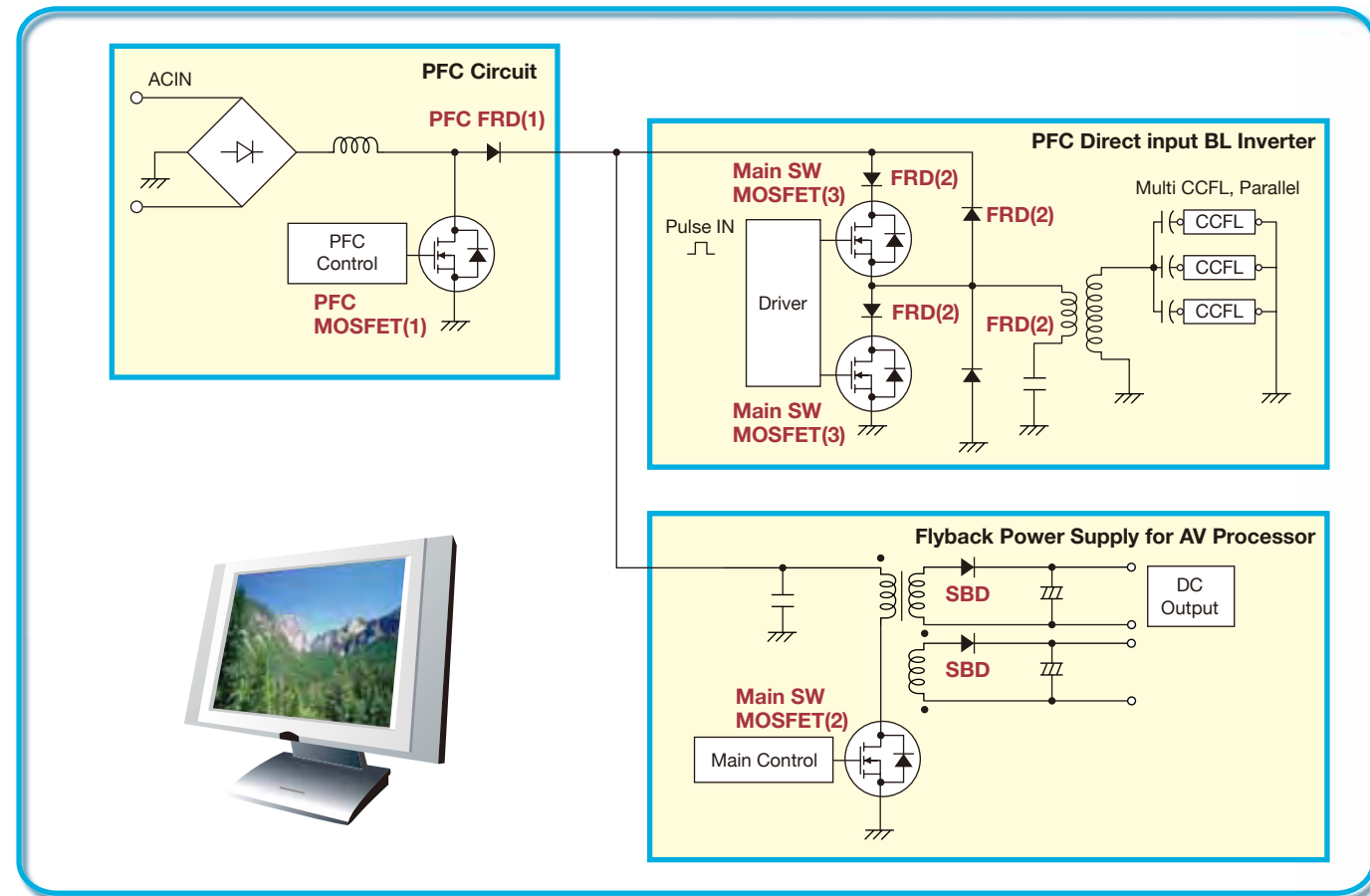

### ◆ Lineup

Set Spec			PFC		Direct BL Inverter		SPS for AV Processor	2nd Rectifier
Panel Size [inch]	POUT [W]	VOUT [V]	FRD(1)	MOSFET(1)	FRD(2)	MOSFET(3)	MOSFET(2)	SBD
26 to 37	200	12	* RD1006LS	2SK4085LS	* RD0506LS	2SK4086LS×2	2SK4098LS	SBT100-16JS
37 to 42	250	12 to 18	* RD1006LS	2SK4124×2	* RD0506LS	2SK4086LS×2	2SK4098LS	SBT100-16JS×2
at least 42	350	12 to 18	* RD1006LS	2SK4124×3	* RD1006LS	2SK4085LS×2	2SK4101LS	SBT100-16JS×2

\*: Development

## (3) Devices for BL Inverter

### 1) Recommended Devices for Bridge Circuit

#### Push-Pull Type

#### [Feature]

- Compared with half-bridge type, although doubled voltage is needed, meanwhile RDS(on) can be suppressed due to the use of Nch, so a good symmetry can be achieved.
- Because the current capacity is large, multi tubes driving can be made possible, and the needed parts count can be reduced.

Separately-excitation	Package	Polarity	Type No.	Set Size [inch]	V <sub>IN</sub> [V]
	SMP	Nch	2SK3285 (30V/34mΩ)	21 to 32	up to 12
		Nch	2Sk3352 (30V/21mΩ)		15 to 24
		Nch	2SK3816 (60V/41mΩ)	at least 60	at least 60
		Nch	2SK3818 (60V/18mΩ)		
		Nch	2SK2592 (250V/200mΩ)		
	TO-220ML TO-220FI	Nch	2SK3703 (60V/28mΩ)	at least 32	15 to 24
		Nch	2SK3704 (60V/15mΩ)		
		Nch	2SK2160 (200V/350mΩ)		
		Nch	2SK2161 (200V/250mΩ)		
		Nch	2SK4096 (500V/710mΩ)		
	VEC8 (VECxxxx) ECH8 (ECH8xxx) TSSOP8 (FTSxxxx(single)) (FTDxxxx(Dual))	Nch + Nch	VEC2402 (30V/99mΩ)	2.5 to 8	5 to 12
		Nch + Nch	ECH8606 (30V/75mΩ)		15 to 24
		Nch	ECH8402 (30V/32mΩ)	15 to 19	15 to 24
		Nch + Nch	FTD8009 (30V/33mΩ)		
		Nch + Nch	ECH8616 (60V/133mΩ)		
	SOP8 (FSSxxxx(single)) (FWxxxx(Dual))	Nch + Nch	FW241 (30V/150mΩ)	at least 32	5 to 12
		Nch + Nch	FW261 (30V/83mΩ)		
		Nch + Nch	FW803 (30V/27mΩ)		
		Nch	FSS250 (30V/54mΩ)		
		Nch	FSS804 (30V/20mΩ)		
Nch + Nch		FW808 (30V/37mΩ)			
Nch + Nch		FW250 (60V/215mΩ)			
Nch + Nch		FW256 (60V/84mΩ)			
Nch+Nch		FSS273 (45V/34mΩ)			
Nch+Nch		FW248 (45V/42mΩ)			
Nch	FSS275 (60V/62mΩ)				
TP SMP	Nch + Nch	FW257 (100V/220mΩ)	at least 120	at least 120	
	Nch + Nch	FW225 (450V/11.2Ω)			
	Nch	SFT1402 (35V/40mΩ)			
	Nch	SFT1403 (35V/25mΩ)			
	Nch	2SK3352 (30V/21mΩ)			
	Nch	SFT1407 (45V/29mΩ)			
	Nch	SFT1405 (45V/74mΩ)			
	Nch	2SK3615 (60V/85mΩ)			
	Nch	2SK3816 (60V/41mΩ)			
	Nch	2SK3818 (60V/18mΩ)			
Nch	2SK1920 (250V/700mΩ)				
Nch	2SK3092 (400V/2.3Ω)				
Nch	2SK3850 (600V/18.5Ω)				

## Full-bridge Type, Half-bridge Type

### [Feature: Full-bridge/Half-bridge Type]

- Pch/Nch drive
- A large current device can drive multi tubes, thus the needed parts count can be reduced.

### [Feature: Half-bridge Type (High voltage input)]

- A highly effective system can be achieved by using a high side driver, which can make the inverter circuit to be operated at a PFC voltage level.  
MOSFET should be Nch type and withstand a high voltage.

Separately-excitation	Package	Polarity	Type No.	Set Size [inch]	V <sub>IN</sub> [V]
	SMP	Nch	2SK3815 (60V/55mΩ)	at least 32	12 to 24
		Pch	2SJ659 (60V/133mΩ)		
		Nch	2SK3819 (100V/130mΩ)		at least 60
		Pch	2SJ664 (100V/136mΩ)		
	TO-220ML TO-220FI	Nch	2SJ3702 (60V/55mΩ)	at least 32	12 to 24
		Pch	2SJ650 (60V/135mΩ)		
		Nch	2SK3706 (100V/130mΩ)		
		Pch	2SJ655 (100V/136mΩ)		
		Nch	2SK2161 (200V/350mΩ)		
		Pch	2SJ405 (200V/500mΩ)		
	VEC8 (VECxxxx) ECH8 (ECH8xxx)	Nch + Pch	VEC2602 (30V/99•168mΩ)	2.5 to 8	5 to 12
		Nch + Pch	ECH8609 (30V/75•120mΩ)		
Nch		ECH8402 (30V/32mΩ)			
Pch		ECH8302 (30V/48mΩ)			
Nch + Nch		ECH8616 (60V/133mΩ)	15 to 24		
Pch + Pch		ECH8615 (60V/295mΩ)			
Nch + Pch		FW344 (30V/150•147mΩ)			
Nch + Pch		FW340 (30V/83•98mΩ)			
SOP8 (FSSxxxx(single)) (FWxxxx(Dual))	Nch + Pch	FW342 (30V/52•98mΩ)	15 to 19	5 to 12	
	Nch	FSS802 (30V/26mΩ)			
	Pch	FSS163 (30V/31mΩ)			
	Nch + Pch	FW349 (30V/84•106mΩ)			
	Nch + Pch	FW359 (30V/215•205mΩ)			
	Nch	FSS273 (45V/34mΩ)		15 to 24	
	Pch	FSS145 (45V/40mΩ)			
	Nch	2SK3351 (30V/21mΩ)			
	Pch	2SJ646 (30V/154mΩ)			
	TP SMP	Nch		2SK3285 (30V/34mΩ)	at least 32
Nch		2SK3352 (30V/21mΩ)			
Nch		SFT1402 (35V/69mΩ)			
Pch		SFT1302 (35V/111mΩ)			
Nch		SFT1405 (45V/74mΩ)			
Pch		SFT1305 (45V/147mΩ)			
Nch		2SK3615 (60V/85mΩ)	15 to 24		
Pch		2SJ635 (60V/92mΩ)			
Nch		2SK3818 (60V/18mΩ)			
Pch		2SJ662 (60V/38mΩ)			
Nch		2SK3979 (200V/450mΩ)			
Pch		2SJ679 (200V/980mΩ)			
at least 120		Nch	2SK1920 (250V/700mΩ)		
		Pch	2SJ281 (250V/2Ω)		

## Self-excitation Type (collector resonance)

### [Feature]

- Multi tubes can be driven by using a power device with large current capacity.  
→ also, the number of inverter circuits and used parts can be reduced.
- 4 to 8 tubes can be driven by circuit.
- Best choice for low-cost sets.

Self-excitation	Package	Type No.	Set Size [inch]	V <sub>IN</sub> [V]
	SMP	2SC5915 (120V/10A)	at least 32	15 to 24V
		2SC5999 (120V/25A)		
	TO-220ML TO-220FI	2SC5888 (80V/10A)	at least 32	up to 15V
		2SC6080 (80V/13A)		up to 15V
		2SC5264 (800V/5A)		at least 100V

## 2) Recommended Power MOSFETs & Bipolar Transistors by Monitor Size

### [Power MOSFET Lineup by Input Voltage and Monitor Size]

PCP Package			SOP8 Package			TP Package		
Type No.	V <sub>DSS</sub> [V]	I <sub>D</sub> [A]	Type No.	V <sub>DSS</sub> [V]	I <sub>D</sub> [A]	Type No.	V <sub>DSS</sub> [V]	I <sub>D</sub> [A]
2SK3614	60	4	FW250	60	3	2SK3978	200	4
2SK3944	60	2	FW359	60	3	2SK3977	100	4
2SJ632	60	2	FW248	45	6	SFT1202	180	2
2SK3489	30	8	FW349	45	4	SFT1201	150	2.5
2SK3490	30	8				SFT1305	45	10
2SJ616	30	6				SFT1307	45	14
						SFT1405	45	10
						SFT1407	45	14
						SFT1403	35	11
						SFT1402	35	14

**20** **32**

### [Bipolar Transistor Lineup by Input Voltage and Monitor Size]

VEC8 Package			PCP Package			TP Package			SMP Package		
Type No.	V <sub>CES</sub> [V]	I <sub>C</sub> [A]	Type No.	V <sub>CES</sub> +V <sub>CB0</sub> [V]	I <sub>C</sub> [A]	Type No.	V <sub>CES</sub> +V <sub>CB0</sub> [V]	I <sub>C</sub> [A]	Type No.	V <sub>CES</sub> [V]	I <sub>C</sub> [A]
VEC2202	120	2.5	PCP1201	150	2.5	2SC6071	120	10	2SC5974	700	7
VEC2201	100	3	PCP1202	180	2	2SD1816	120*	4	2SC5999	120	25
			2SC6095	120	2.5	2SD1815	120*	3	2SC5915	120	10
			2SC6096	120	2	2SC6098	120	2.5			
			2SC3647	120*	2	2SC6099	120	2			
			2SC5991	100	7	2SC5980	100	8			
			2SC5990	100	4	2SC5979	100	5			
			2SC5964	100	3	2SC5707	80	8			
			2SC5994	100	2	2SC5706	80	5			
						2SC6022	40*	9			
						2SC6020	40*	6			

**8** **20** **32**



## (4) Devices for Power MOSFET Buffer

### 1) Low Side Driver ExPD [MOSFET, IGBT Gate driver IC]

#### [Application]

- PDP, LCD-backlight, inverter light, liquid crystal projector, HID drive, motor drive, half-bridge/full-bridge power supply, etc.

#### [ExPD Use Example]

- Withstand voltage of 25V is assured.
- 2 low side drivers in
- TTL/CMOS compatible  
( $V_{IH}=2.6V$  or less at  $V_{DD}=4.5$  to  $25V$ )
- High-speed switching time  
( $t_r/t_f=typ$  25ns, at 1000pF load [TND301S])

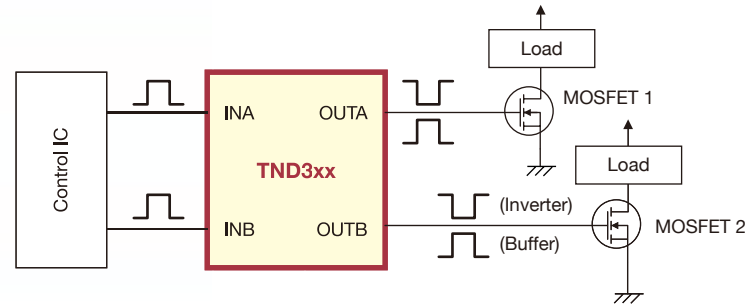

#### ExPDs

Type No.	Package	Functions	VDD max [V]	Pd max [W]	Operating voltage range [V]	Drive capability		V <sub>IH</sub> min [V]	V <sub>IL</sub> max [V]
						Source [A]	Sink[A]		
TND321VD	VEC8	Dual inverter	25	0.2	4.5 to 25	0.8	1	2.6	0.8
TND322VD		Dual buffer	25	0.2	4.5 to 25	0.8	1	2.6	0.8
TND323VD		Inverter buffer	25	0.2	4.5 to 25	0.8	1	2.6	0.8
TND307TD	TSSOP8	Dual inverter	25	0.25	4.5 to 25	1	1	2.6	0.8
TND308TD		Dual buffer	25	0.25	4.5 to 25	1	1	2.6	0.8
TND309TD		Inverter buffer	25	0.25	4.5 to 25	1	1	2.6	0.8
TND301S	SOP8	Dual inverter	25	0.3	4.5 to 25	2	2	2.6	0.8
TND302S		Dual buffer	25	0.3	4.5 to 25	2	2	2.6	0.8
TND303S		Inverter buffer	25	0.3	4.5 to 25	2	2	2.6	0.8
TND304S		Dual inverter	25	0.3	4.5 to 25	1	1	2.6	0.8
TND305S		Dual buffer	25	0.3	4.5 to 25	1	1	2.6	0.8
TND306S		Inverter buffer	25	0.3	4.5 to 25	1	1	2.6	0.8
TND311S		Dual inverter	25	0.3	4.5 to 25	2	2	2.6	0.8
TND312S		Dual buffer	25	0.3	4.5 to 25	2	2	2.6	0.8
TND313S		Inverter buffer	25	0.3	4.5 to 25	2	2	2.6	0.8
TND314S		Dual inverter	25	0.3	4.5 to 25	1	1	2.6	0.8
TND315S		Dual buffer	25	0.3	4.5 to 25	1	1	2.6	0.8
TND316S		Inverter buffer	25	0.3	4.5 to 25	1	1	2.6	0.8

\* TND30x series: input terminal Hi Z (high impedance); TND31x/TND32x series: input pull-down resistor in.

## 2) High Voltage Driver ExPD

### [ExPD Use Example]

- High withstand voltage driver (600V)
- Under-voltage protection function is built in

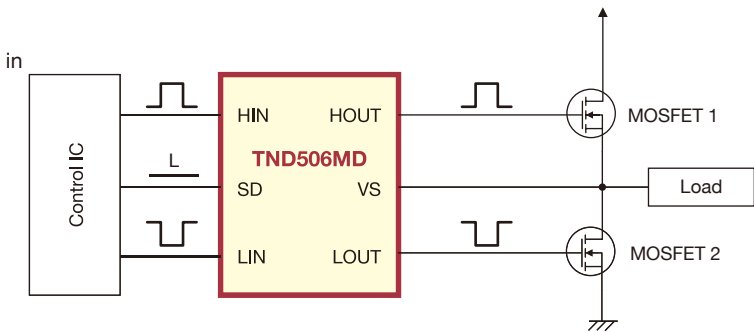

#### ExPDs

Type No.	Package	VS [V]	IO		Features	Applications
			Source [mA]	Sink [mA]		
● TND516SS	SOP8	600	200	400	Single-phase high side driver	Ballasts, PDP maintenance drive, DC/AC motor drive, induction heaters, charging circuits, high-frequency switching power supplies, switching amplifiers, and other general-purpose driver applications
TND507S		600	250	500	Single input/two output half bridge driver circuits	
TND508S		600	250	500		
● TND512MD	MFP16	600	200	400	3-phase high side driver	3-phase motor drive application
TND505MD		600	250	500	Two input/output half bridge driver circuits. Built-in shutdown function and low-side priority circuit.	PDP maintenance drive, DC/AC motor drive, ballasts, charging circuits, high-frequency switching power supplies, induction heaters, switching amplifiers, and other general-purpose driver applications
TND506MD		600	250	500	Two input/output half bridge driver circuits. Built-in shutdown function.	

## 3) LCD-Backlight Inverter: ExPD

[TND3xx Use Example: MOSFET Driver]

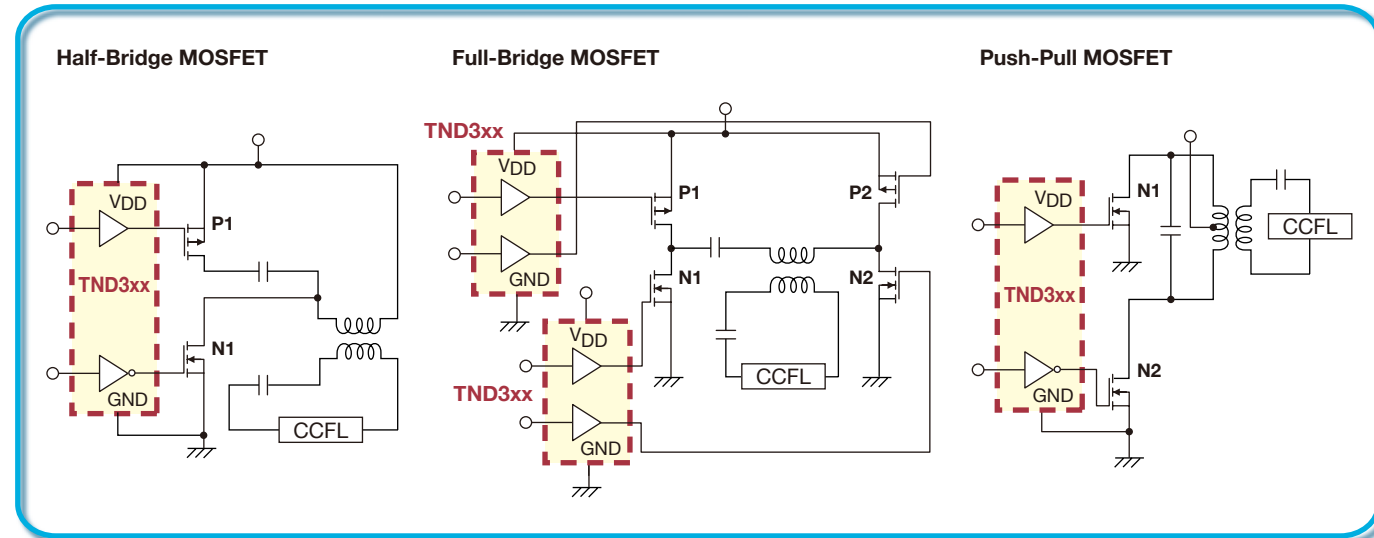

[TND3xx Use Example: High-side FET Drive, Various Applications]

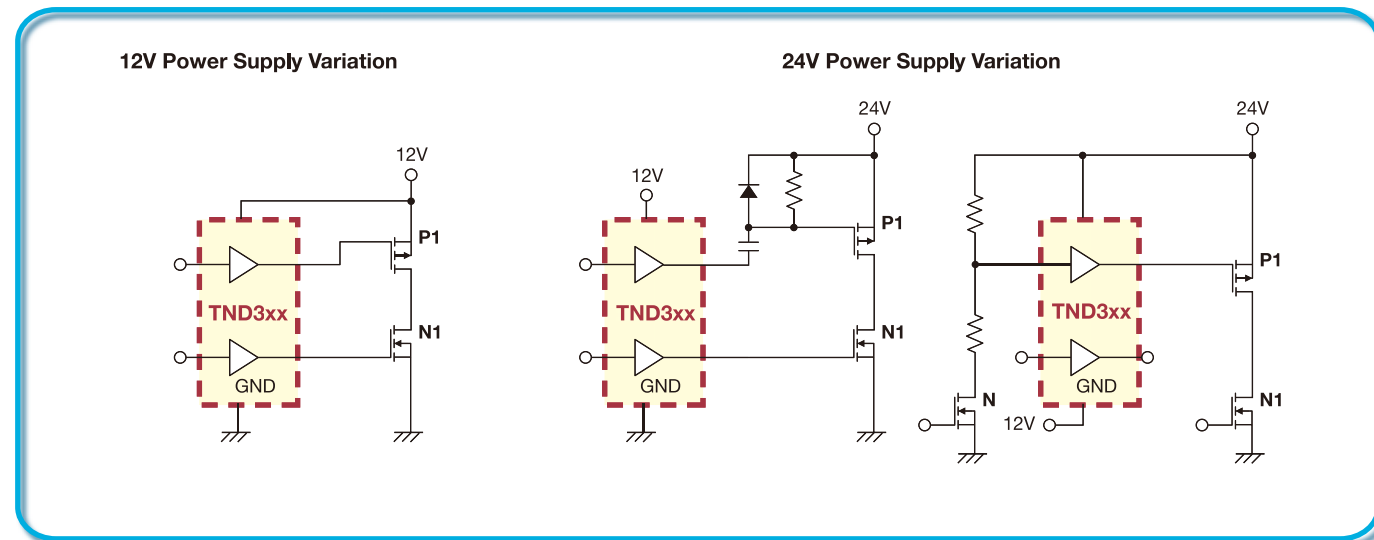

## 4) PDP Sustain Driver: ExPD

[TND5xx, TND3xx Use Example]

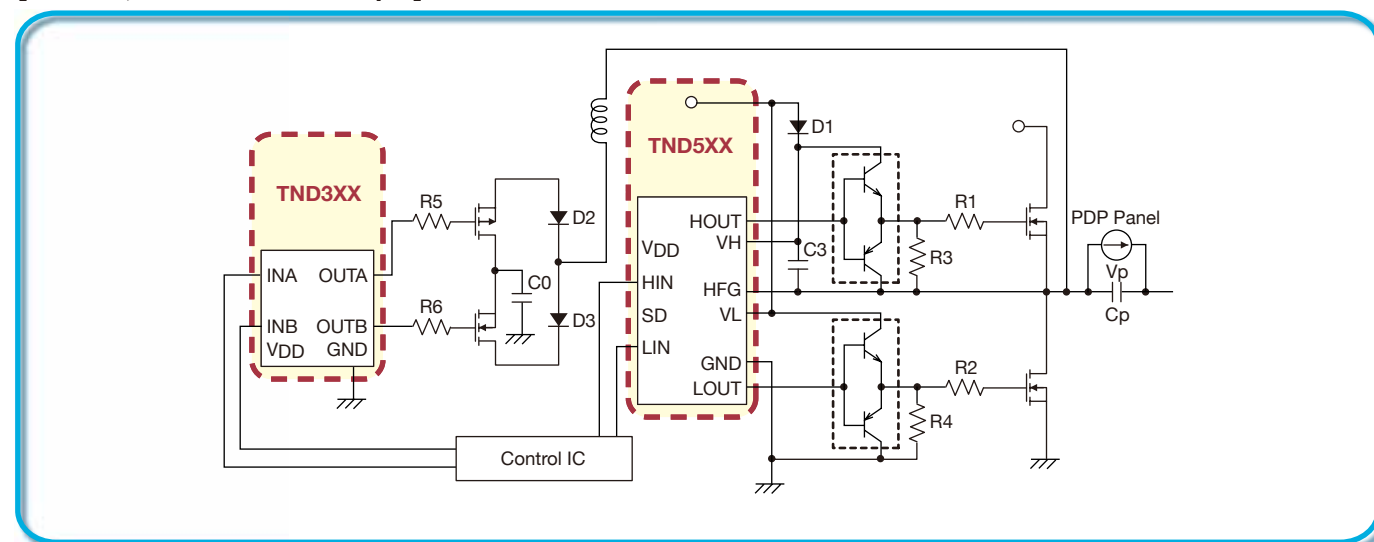

## 5) Air conditioner fan motor drive: ExPD

[TND512MD Use Example]

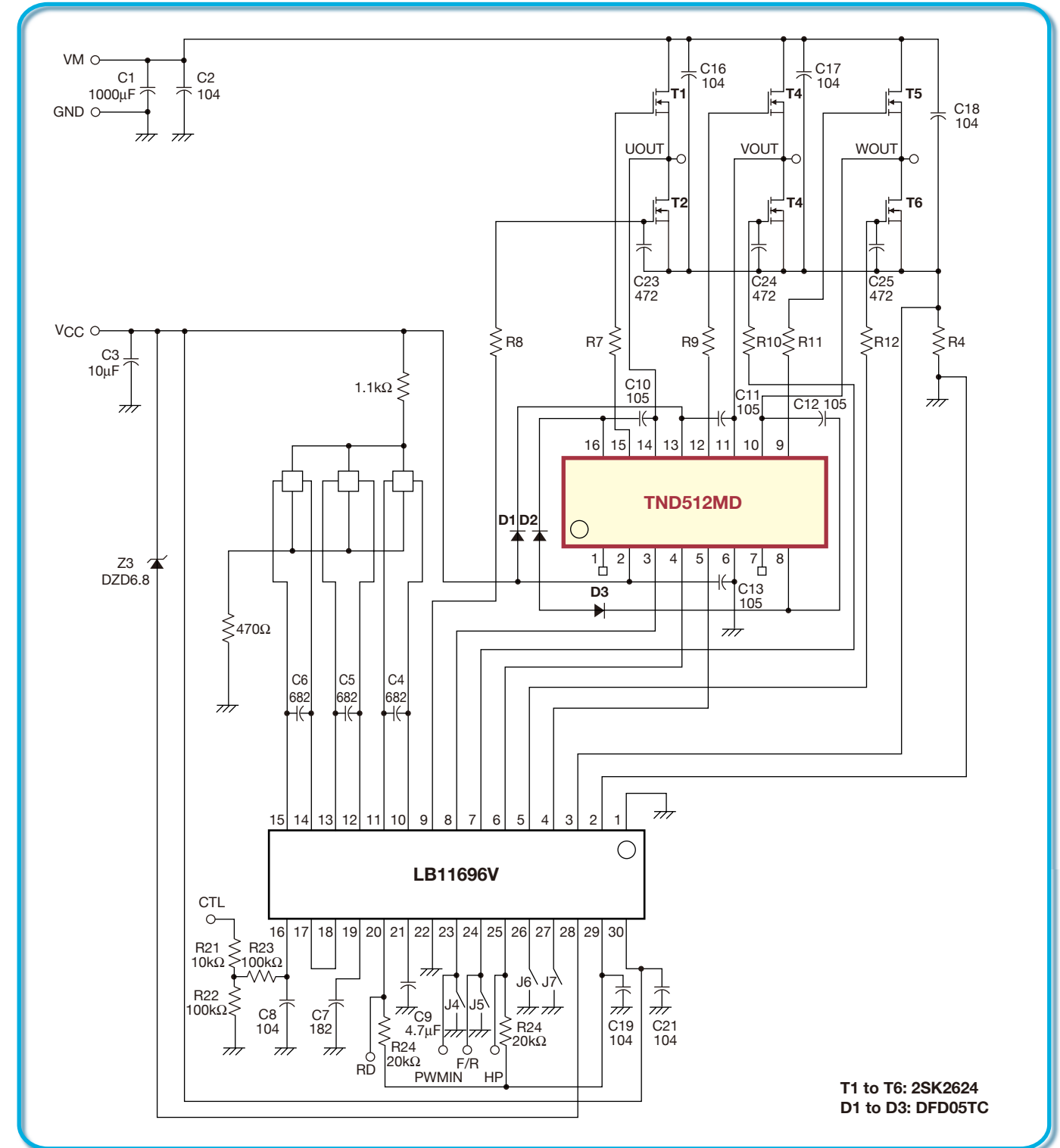

T1 to T6: 2SK2624  
D1 to D3: DFD05TC



## 6) Bipolar Transistors: Separately-excited Inverter (MOSFET for Gate Drive)

### [Bipolar Transistor Use Example]

- IC with large IC is recommended for driving large-capacitance MOSFET
- Composite type (PNP+NPN) is recommended for miniaturization purpose

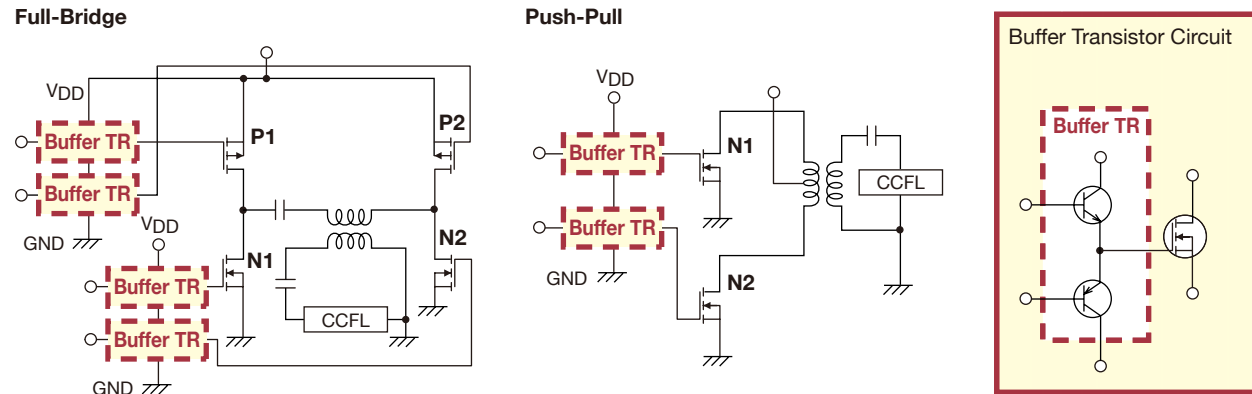

### Bipolar Transistors

Type No.	Package	Polarity	Absolute maximum ratings/Ta=25°C				Electrical characteristics/Ta=25°C								Internal chip equivalent product	Electrical connection
			VCE0 [V]	IC [A]	ICP [A]	PC [W]	hFE		VCE (sat) [V]							
							VCE [V]	IC [A]	min	max	IC [A]	IB [mA]	typ	max		
MCH5541	MCPH5	PNP	30	0.7	3	0.5	2	0.01	200	500	0.2	10	0.11	0.22	30A02MH +30C02MH	B14
		NPN	30	0.7	3	0.5	2	0.05	300	800	0.2	10	0.085	0.19		
MCH6542	MCPH6	PNP	30	0.3	0.9	0.5	2	0.01	200	500	0.1	5	0.11	0.22	30A01M +30C01M	B13
		NPN	30	0.3	0.9	0.5	2	0.01	300	800	0.1	5	0.1	0.2		
MCH6545	MCPH6	PNP	50	0.5	1	0.5	2	0.01	200	500	0.1	10	0.06	0.12	50A02CH +50C02CH	B13
		NPN	50	0.5	1	0.5	2	0.01	300	700	0.1	10	0.05	0.1		
CPH5541	CPH5	PNP	30	0.7	3	0.6	2	0.01	200	500	0.2	10	0.11	0.22	30A02CH +30C02CH	B14
		NPN	30	0.7	3	0.6	2	0.05	300	800	0.2	10	0.085	0.19		
CPH5506	CPH5	PNP	30	1.5	5	0.9	2	0.1	200	560	0.75	15	0.25	0.375	CPH3115 +CPH3215	B14
		NPN	30	1.5	5	0.9	2	0.1	200	560	0.75	15	0.15	0.225		
CPH5516	CPH5	PNP	30	2	6	0.9	2	0.1	200	560	1.5	75	0.17	0.26	CPH3144 +CPH3244	B14
		NPN	30	2	6	0.9	2	0.1	200	560	1.5	75	0.16	0.24		
CPH5518	CPH5	PNP	50	1	3	0.9	2	0.1	200	560	0.5	10	0.23	0.38	CPH3116 +CPH3216	B14
		NPN	50	1	3	0.9	2	0.1	200	560	0.5	10	0.13	0.19		
CPH5524	CPH5	PNP	50	3	6	0.9	2	0.1	200	560	1	50	0.115	0.23	CPH3123 +CPH3223	B14
		NPN	50	3	6	0.9	2	0.1	200	560	1	50	0.09	0.13		

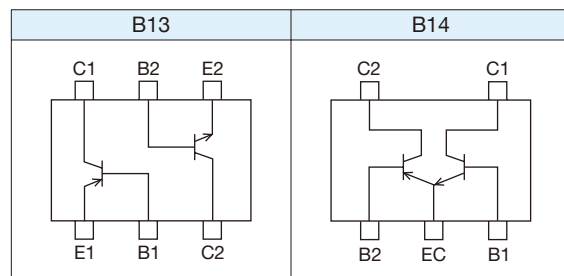

## DC-DC Converter IC

### TN8D41A/51A, TN5D41A/51A/61A: Separately-excited step-down switching regulator

#### [Functions/Features]

- Large current  $I_O$  max 8A (TN8D41A/51A)  $I_O$  max 5A (TN5D41A/51A/61A)
- High efficiency Vertical-type P-channel power MOSFET built-in
- High withstand voltage  $V_{IN}$  max 57V
- Five external parts
- Built-in reference oscillator (150kHz)
- Built-in current limiter
- Built-in thermal shutdown circuit
- Built-in soft start circuit
- ON/OFF function (shared with soft start pin)

Type No.	Type	Input voltage	Output voltage/current	Channels	Power stage	Package
TN5D41A	Step-down	10V to 40V	5V/5A	1ch	Built-in (PMOS)	TO-220F15H-HB
TN8D41A	Step-down	10V to 40V	5V/8A	1ch	Built-in (PMOS)	TO-220F15H-HB
TN5D51A	Step-down	20V to 48V	12V/5A	1ch	Built-in (PMOS)	TO-220F15H-HB
TN8D51A	Step-down	20V to 48V	12V/8A	1ch	Built-in (PMOS)	TO-220F15H-HB
TN5D61A	Step-down	30V to 48V	24V/5A	1ch	Built-in (PMOS)	TO-220F15H-HB

### [ExPD Use Example]

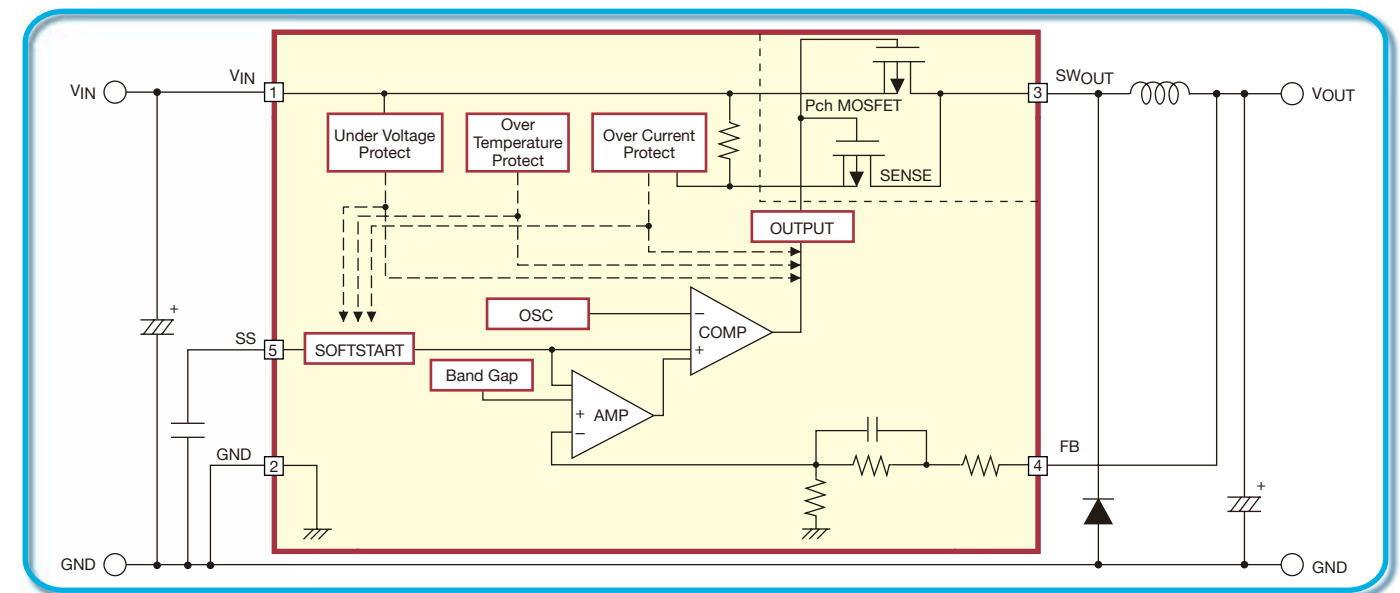

### [Application Example for Power Supply Makers: Allows High Design Freedom]

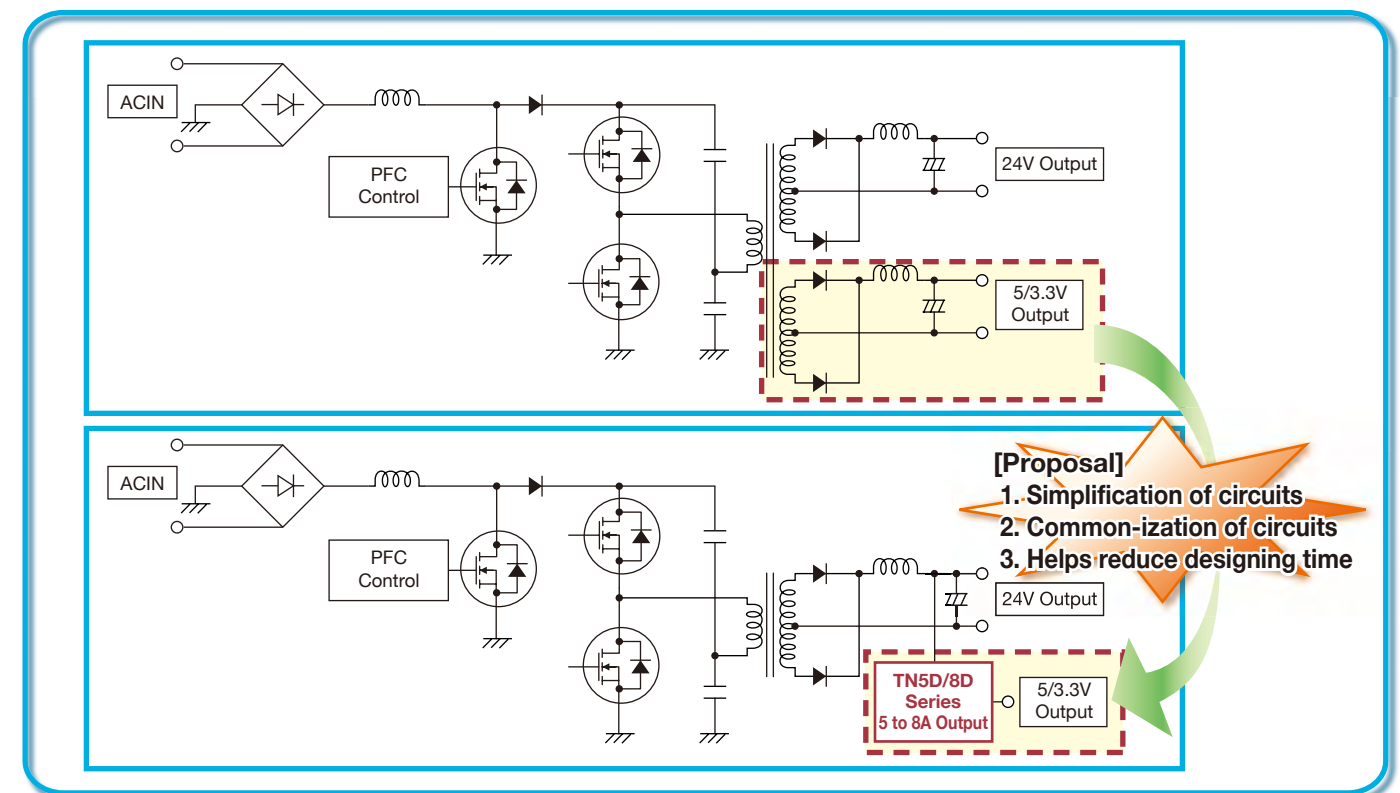

## ■ Inverter light

[Bipolar Transistor Use Example: Ball Lamp]

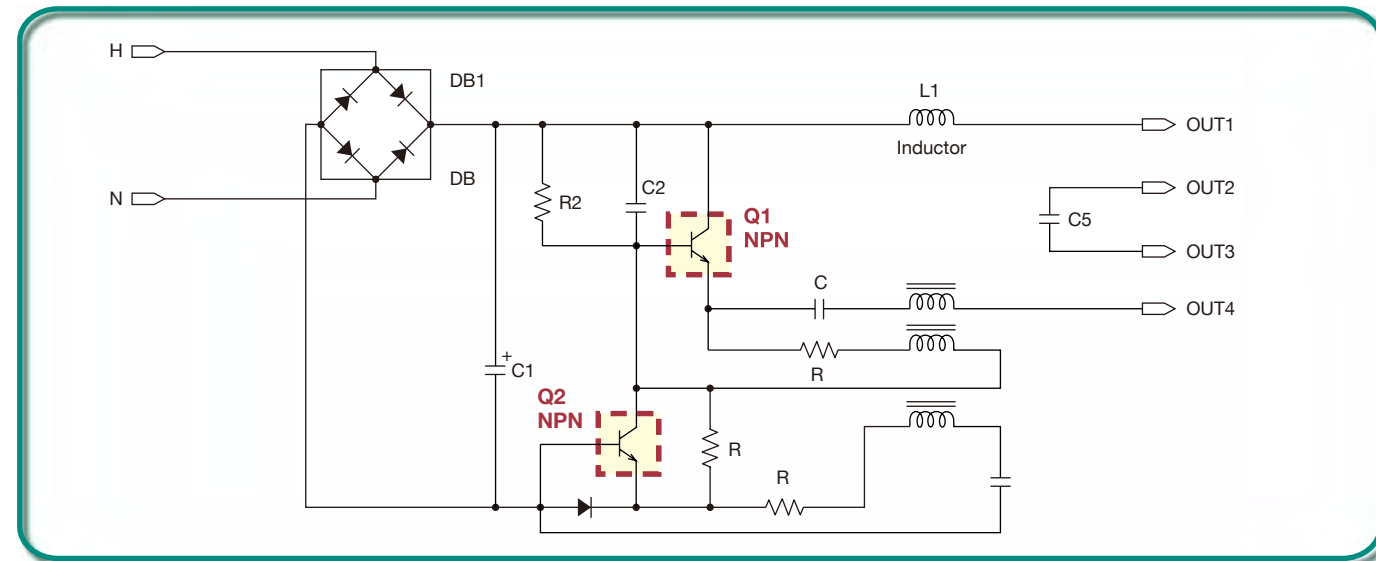

### Bipolar Transistors

Type No.	Package	Polarity	Absolute maximum ratings/Ta=25°C			Electrical characteristics/Ta=25°C						Merit	Set power [W]	
			VCBO [V]	VCEO [V]	IC [A]	hFE1				hFE2				
						VCE [V]	IC [A]	min	max	VCE [V]	IC [A]			
TT2264	SPA	NPN	700	400	0.3	5	0.03	50	100	5	0.15	at least 10	hFE of low current side is high	up to 20
2SC6083A		NPN	700	400	1	5	0.1	50	100	5	0.5	at least 10	hFE of low current side is high, package is small	20 to 60
TT2240NMP	NMP	NPN	700	400	1	1	0.1	15	30	5	0.5	at least 10	Package is small	20 to 60
TT2188	TO-220	NPN	500	400	5	5	0.5	20	50	5	3	at least 10	tf=0.3μs	20 to 60
TT2146		NPN	500	400	8	5	0.8	20	50	5	4	at least 10	tf=0.3μs	65 to 130
TT2196		NPN	500	400	12	5	1.2	20	50	5	6	at least 10	tf=0.3μs	

[MOSFET Use Example: Ball Lamp]

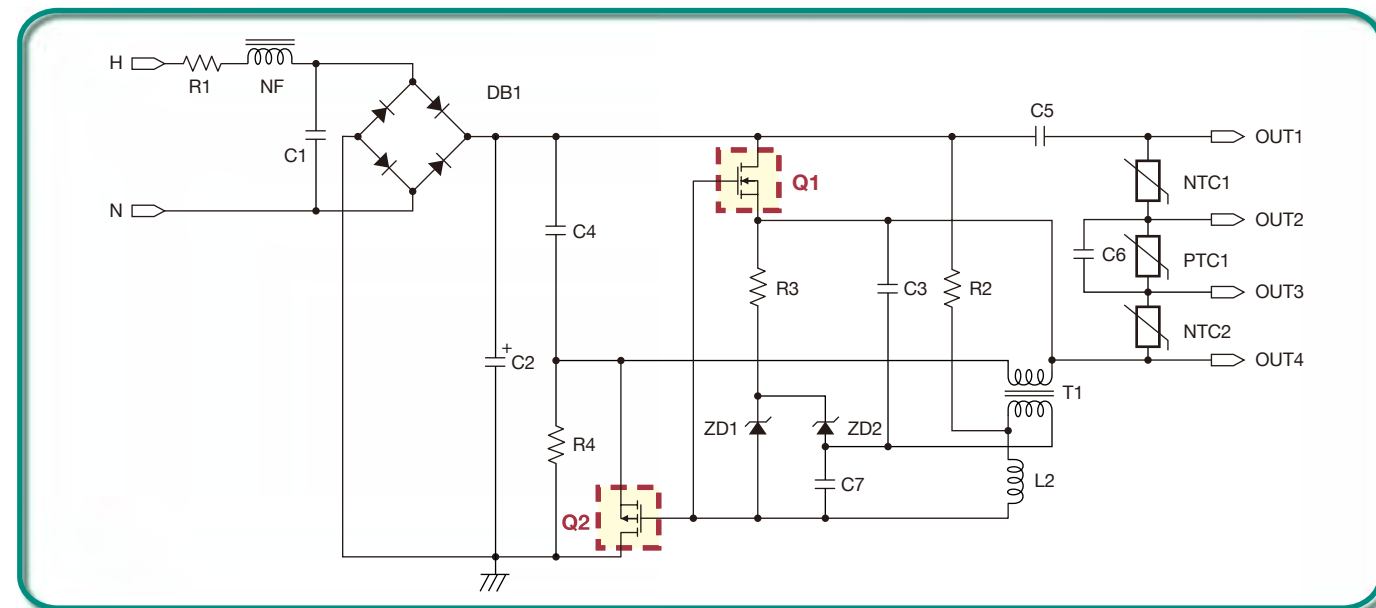

### MOSFETs

Type No.	Package	Polarity	Absolute maximum ratings/Ta=25°C				Electrical characteristics/Ta=25°C					
			VDSS [V]	VGSS [V]	ID [A]	PD [W]	RDS(on) [Ω]				Ciss [pF]	Qg [nC]
							VGS=10(15)V		VGS=4(4.5)V			
				typ	max	typ	max					
2SJ281	PCP	Pch	250	30	3	30	1.5	2	-	-	420	-
● 2SK3979		Nch	200	30	6	20	0.32	0.45	-	-	1090	18.2
2SK1920		Nch	250	30	4	30	0.5	0.7	-	-	420	-

[MOSFET Use Example]

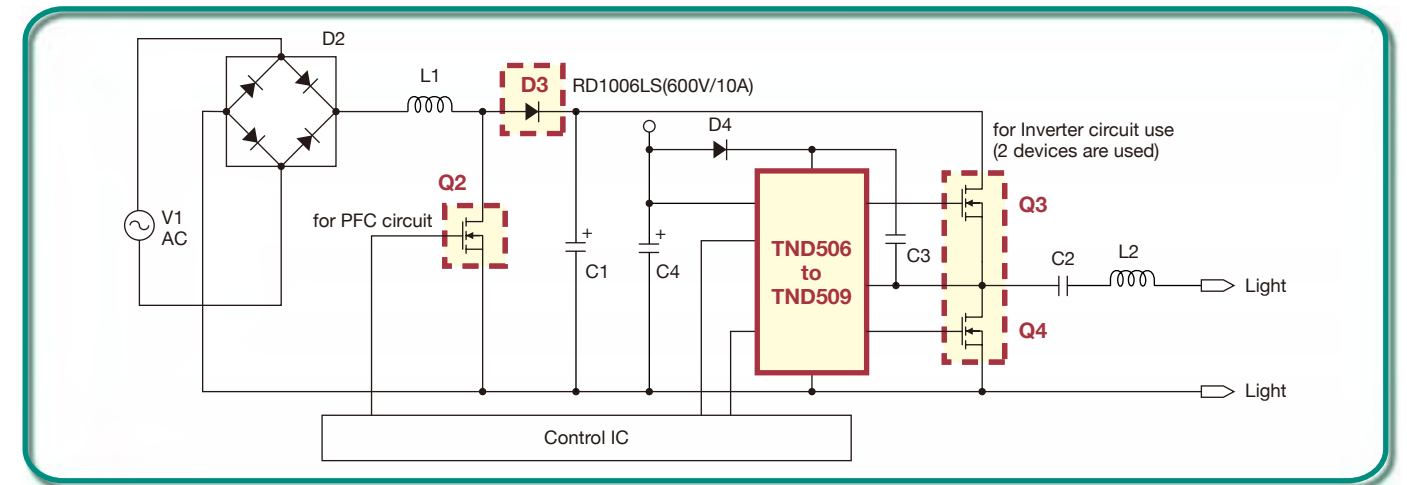

### Recommended Devices and Spec: Surface Mount Type

Recommended devices by inverter lighting set [AC=200V input]

Set output (Fluorescent tube) [W]	PFC circuit	Inverter circuit	Remarks
32×2	2SK4136×2 2SK4181×2	2SK4136×2 2SK4181×2	525V device is recommended when a larger margin is needed.
40×2	2SK4137×2 2SK4182×2	2SK4136×2 2SK4181×2	<b>[ZP Package]</b> • good surface radiation due to thin body PD up better radiation than that of SMP package. 10% PD up.
86×2	2SK4138×2 2SK4183×2	2SK4138×2 2SK4183×2	

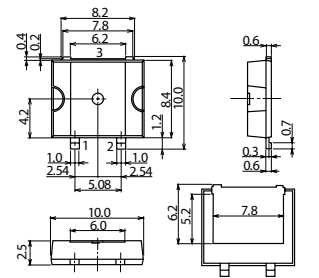

### MOSFETs

Type No.	Package	Absolute maximum ratings/Ta=25°C				Electrical characteristics/Ta=25°C		
		VDSS [V]	VGSS [V]	ID [A]	PD Tc=25°C [W]	RDS(on) [Ω]		Ciss [pF]
						typ	max	
● 2SK4136	ZP	500	30	8	70	0.65	0.85	600
● 2SK4137		500	30	9.5	80	0.5	0.65	750
● 2SK4138		500	30	14	100	0.4	0.52	1000
● 2SK4181		525	30	7.5	70	0.71	0.92	600
● 2SK4182		525	30	9	80	0.58	0.75	750
● 2SK4183		525	30	13	100	0.45	0.58	1000

### Recommended Devices and Spec: Lead Type

Recommended devices by inverter lighting set [AC=200V input]

Set output (Fluorescent tube) [W]	PFC circuit	Inverter circuit	Remarks
40×2	2SK4186LS	2SK4198LS×2	<b>[TO-220FI(LS) Package]</b>
86×2	2SK4186LS×2	2SK4199LS×2	
86×3	2SK4187LS×2	2SK4187LS×2	

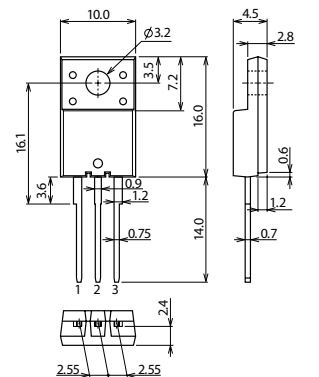

### MOSFETs

Type No.	Package	Absolute maximum ratings/Ta=25°C				Electrical characteristics/Ta=25°C			
		VDSS [V]	VGSS [V]	ID [A]	PD Tc=25°C [W]	RDS(on) [Ω]		Ciss [pF]	Qg [nC]
						typ	max		
● 2SK4098LS	TO-220FI(LS)	600	30	7	33	0.9	1.1	660	-
● 2SK4099LS		600	30	8.5	35	0.72	0.94	815	-
● 2SK4086LS		600	30	11.5*	37	0.58	0.75	1000	38.2
● 2SK4087LS		600	30	14*	40	0.47	0.61	1200	46



Emergency Lamp

[2SK4043LS Use Example]

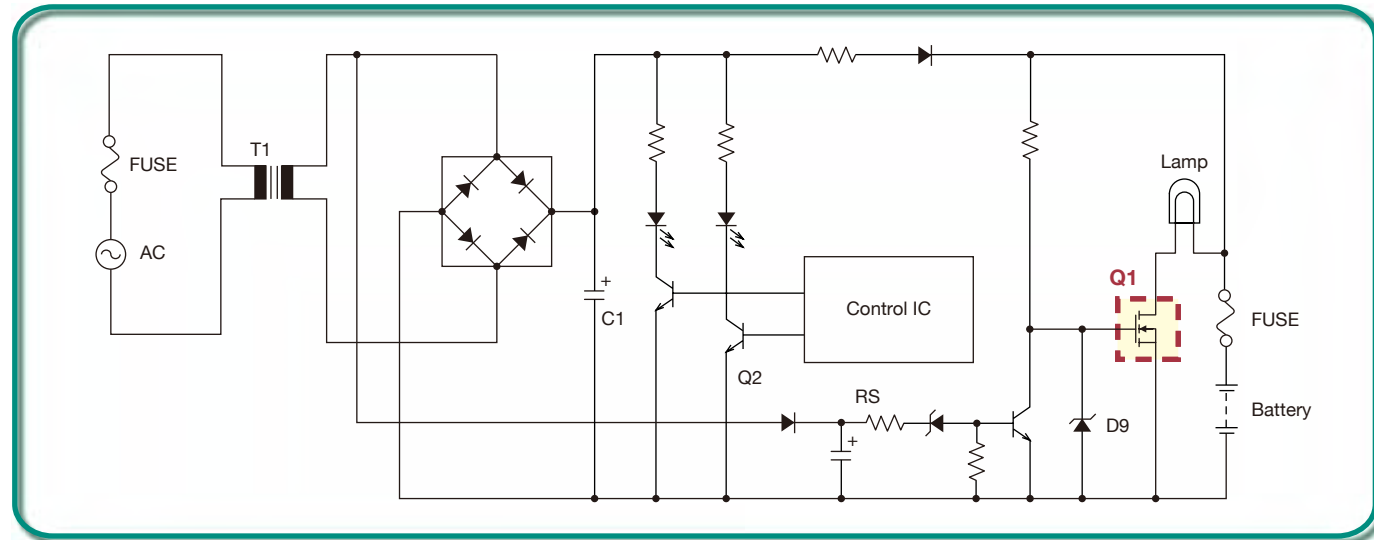

MOSFETs

Type No.	Package	Absolute maximum ratings/Ta=25°C				Electrical characteristics/Ta=25°C					
		VDSS [V]	VGSS [V]	ID [A]	PD Tc=25°C [W]	RDS (on) [Ω]				Ciss [pF]	Qg [nC]
						VGS=2.5V		VGS=4V			
● 2SK4043LS	TO-220F(LS)	30	10	20	20	typ	max	typ	max	3000	37

HID Lamp

[MOSFET Use Example]

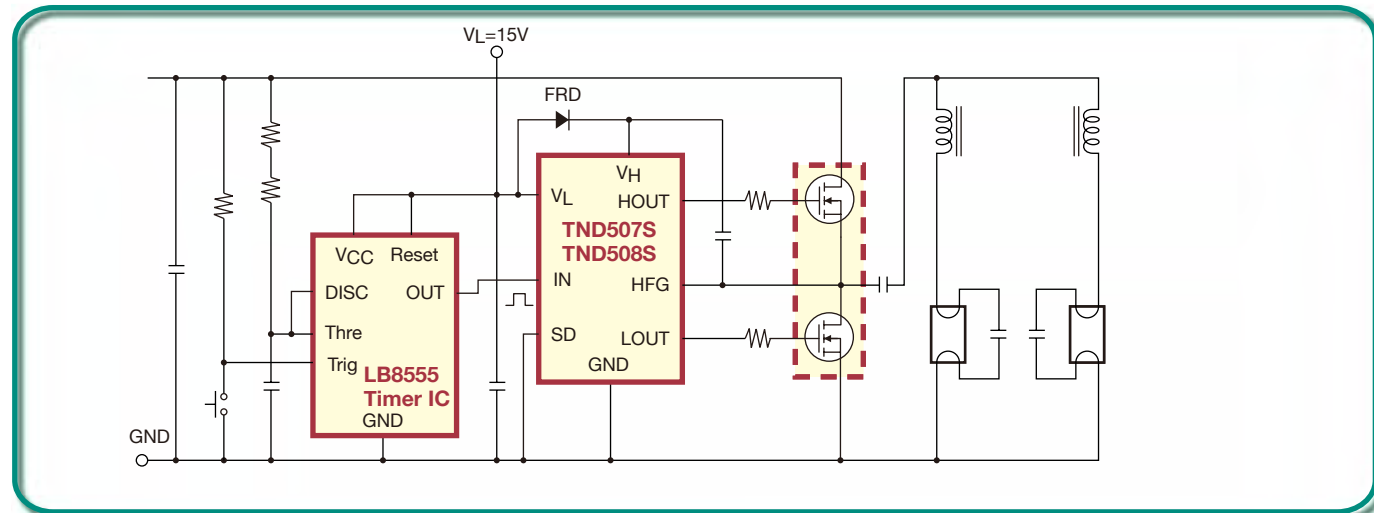

MOSFETs

Type No.	Package	Absolute maximum ratings/Ta=25°C				Electrical characteristics/Ta=25°C			
		VDSS [V]	VGSS [V]	ID [A]	PD Tc=25°C [W]	RDS (on) [Ω]		Ciss [pF]	Qg [nC]
						VGS=10(15)V			
● 2SK4136	ZP	500	30	8	70	0.65	0.85	600	-
● 2SK2617ALS	TO-220F(LS)	500	30	5	25	1.2	1.6	550	15
● 2SK2618ALS		500	30	6.5	30	0.95	1.25	700	20
● 2SK2625ALS		600	30	5	30	1.5	2	700	20
● 2SK4098LS		600	30	7	33	0.9	1.1	660	-

Devices for Modem

[High-Voltage Transistor Use Example for MODEM Circuit]

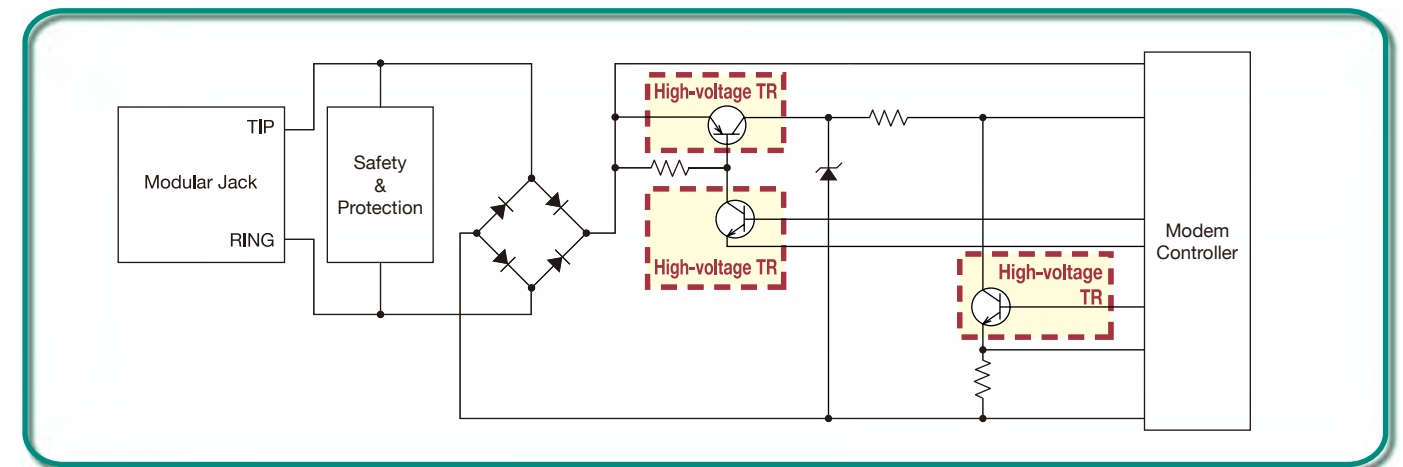

Transistors for Modem Circuit

Type No.	Package	Polarity	Absolute maximum ratings/Ta=25°C			Electrical characteristics/Ta=25°C					
			VCEO [V]	IC [A]	PC [W]	hFE		ft typ [MHz]	VCE (sat) [V]		
						min	max		IC [mA]	IB [mA]	max
2SA1740	PCP	PNP	400	0.2	1.3	60	200	70	50	5	0.8
2SA1699	NP	PNP	400	0.2	0.6	60	200	70	50	5	0.8
2SA1785	NMP	PNP	400	1	1	40	200	50	200	20	1
● CPH3249A	CPH	NPN	400	1	0.6	50	100	20	10	100	0.8
2SC4548	PCP	NPN	400	0.2	1.3	60	200	70	50	5	0.6
2SC4002	NP	NPN	400	0.2	0.5	60	200	70	50	5	0.6
SOP8501	SOP8	PNP	400	1	1.3	40	200	70	0.2	20	1
		NPN	400	0.2	1.3	60	200	70	0.05	5	0.6

\*1: When mounted on ceramic substrate (250mm²×0.8mm)

Devices for infrared sensor

[Junction FET Use Example]

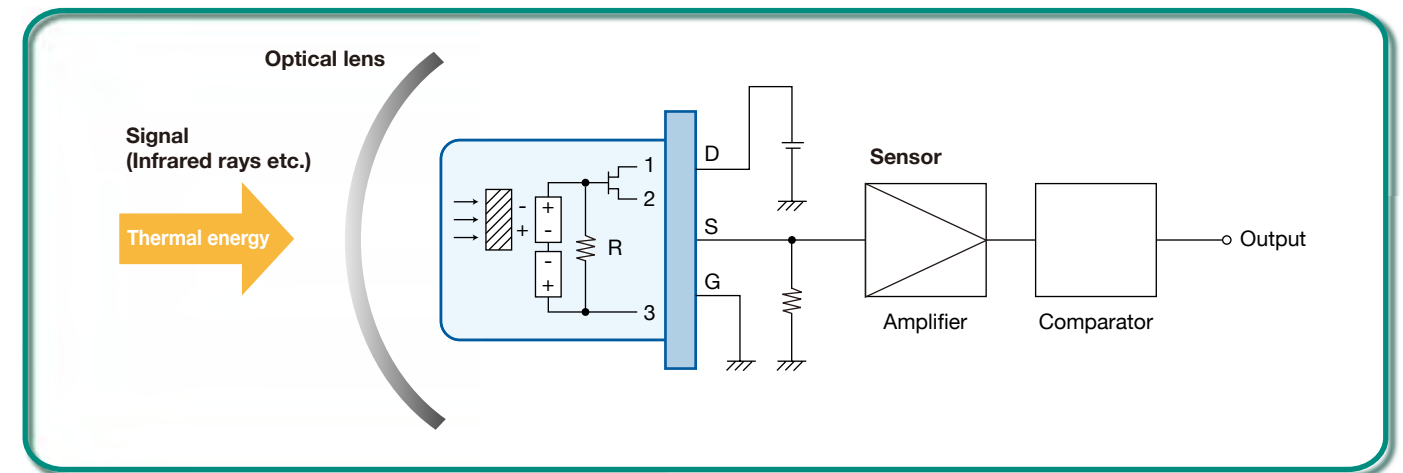

Junction FET

Type No.	Package	Absolute maximum ratings/Ta=25°C				Electrical characteristics/Ta=25°C					Typical Applications
		VDSX [V]	VGDS VGDO [V]	ID [mA]	PD [mW]	IDSS [mA]		yfs  typ [mS]	Ciss typ [pF]	Crss typ [pF]	
						min	max				
● EC3A04B	ECSP1006-3B	30	30	10	100	0.6	3	5	4	1.1	humanbody detection, temp. detection, automatic switching, etc.

■ Satellite LNB

[Satellite LNB]

Frequency: 9 to 14GHz

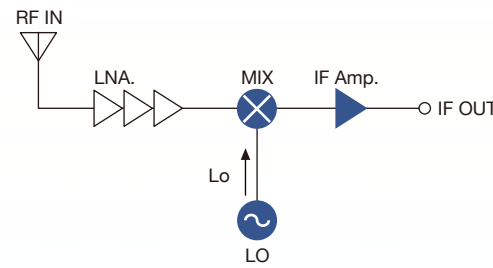

Ultrahigh-Frequency Transistors

Type No.	Package	Absolute maximum ratings/Ta=25°C			Electrical characteristics/Ta=25°C								Block
		VCE0 [V]	IC [mA]	PC [mW]	f <sub>T</sub> typ [GHz]	NF		S <sub>21</sub> e <sup>2</sup>					
						f [GHz]	typ [dB]	f [GHz]	VCE [V]	IC [mA]	typ [dB]		
MCH4009	MCPH4	3.5	40	120	25	2	1.1	2	3	20	17	Lo/IF Amp.	
MCH4011		3.5	100	350	24	2	1.1	2	3	50	14.5	Lo/IF Amp.	
MCH4012		3.5	200	500	20	2	1.0	2	3	100	12	Lo/IF Amp.	
MCH4020		8	150	500	16.5	2	1.2	1	5	50	17.5	Lo/IF Amp.	

High-Frequency Schottky Barrier Diodes

● New products

Type No.	Package	Absolute maximum ratings/Ta=25°C			Electrical characteristics/Ta=25°C			Block
		VR [V]	IF [mA]	P [mW]	V <sub>F</sub> [mV]	Conversion Loss [dB]	C typ [pF]	
● SBX201C	CP	2	50	-	280	8.6	0.25	Mixer

■ GPS/XM Antenna Module

[GPS/XM Antenna Module]

Frequency: 1.57 to 2.3GHz

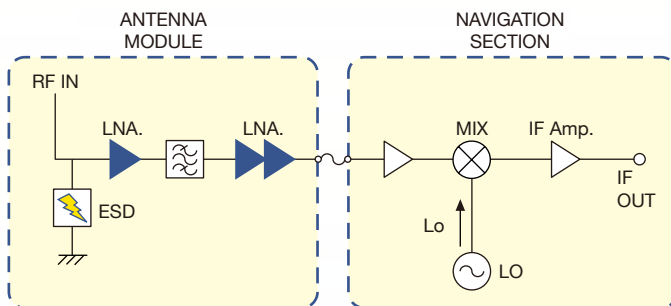

High-Frequency Transistors

Type No.	Package	Absolute maximum ratings/Ta=25°C			Electrical characteristics/Ta=25°C								Block
		VCE0 [V]	IC [mA]	PC [mW]	f <sub>T</sub> typ [GHz]	NF		S <sub>21</sub> e <sup>2</sup>					
						f [GHz]	typ [dB]	f [GHz]	VCE [V]	IC [mA]	typ [dB]		
MCH4009	MCPH4	3.5	40	120	25	2	1.1	2	3	20	17	LNA	
MCH4011		3.5	100	350	24	2	1.1	2	3	50	14.5	LNA	
MCH4012		3.5	200	500	20	2	1.0	2	3	100	12	LNA	
MCH4013		3.5	15	120	22.5	2	1.5	2	5	5	16	LNA	
EC4H08C	ECSP1008	3.5	15	50	24	2	1.5	2	3	10	17	LNA	
EC4H09C		3.5	40	120	26	2	1.3	2	3	20	16.5	LNA	

■ FM Transmitter

[Varactor Diode Use Example]

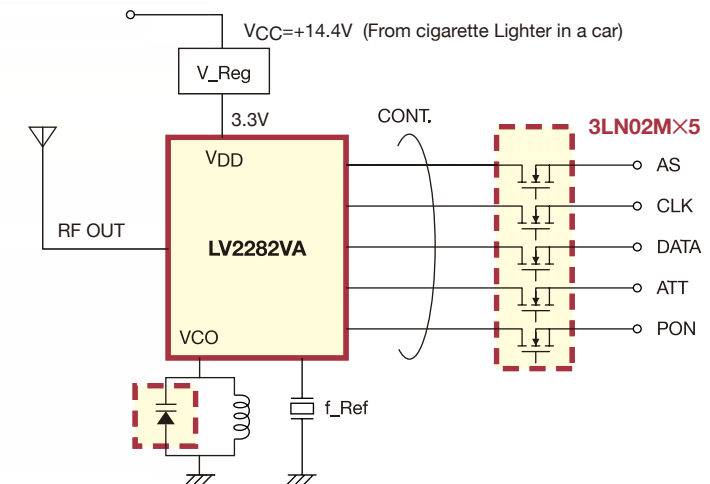

Varactor Diode

Type No.	Package	Absolute maximum ratings/Ta=25°C		Electrical characteristics/Ta=25°C					
		VR [V]	VR [V]	C1		C2		ΔCm [%]	
				min	max	min	max	C1.0V/C4.0V max	
EC2C01C	ECSP1008-2	15	1	18.5	21.5	4	3.5	4.5	5.0
SVC710	MCPH3	15	1	18.5	21.5	4	3.5	4.8	4.8
SVC707	SPA	15	1	18.58	21.26	4	3.61	4.73	3.0

■ Any and all SANYO Semiconductor Co.,Ltd. products described or contained herein are, with regard to "standard application", intended for the use as general electronics equipment (home appliances, AV equipment, communication device, office equipment, industrial equipment etc.). The products mentioned herein shall not be intended for use for any "special application" (medical equipment whose purpose is to sustain life, aerospace instrument, nuclear control device, burning appliances, transportation machine, traffic signal system, safety equipment etc.) that shall require extremely high level of reliability and can directly threaten human lives in case of failure or malfunction of the product or may cause harm to human bodies, nor shall they grant any guarantee thereof. If you should intend to use our products for applications outside the standard applications of our customer who is considering such use and/or outside the scope of our intended standard applications, please consult with us prior to the intended use. If there is no consultation or inquiry before the intended use, our customer shall be solely responsible for the use.

■ Specifications of any and all SANYO Semiconductor Co.,Ltd. products described or contained herein stipulate the performance, characteristics, and functions of the described products in the independent state, and are not guarantees of the performance, characteristics, and functions of the described products as mounted in the customer's products or equipment. To verify symptoms and states that cannot be evaluated in an independent device, the customer should always evaluate and test devices mounted in the customer's products or equipment.

■ SANYO Semiconductor Co.,Ltd. assumes no responsibility for equipment failures that result from using products at values that exceed, even momentarily, rated values (such as maximum ratings, operating condition ranges, or other parameters) listed in products specifications of any and all SANYO Semiconductor Co.,Ltd. products described or contained herein.

■ SANYO Semiconductor Co.,Ltd. strives to supply high-quality high-reliability products, however, any and all semiconductor products fail or malfunction with some probability. It is possible that these probabilistic failures or malfunction could give rise to accidents or events that could endanger human lives, trouble that could give rise to smoke or fire, or accidents that could cause damage to other property. When designing equipment, adopt safety measures so that these kinds of accidents or events cannot occur. Such measures include but are not limited to protective circuits and error prevention circuits for safe design, redundant design, and structural design.

■ In the event that any or all SANYO Semiconductor Co.,Ltd. products described or contained herein are controlled under any of applicable local export control laws and regulations, such products may require the export license from the authorities concerned in accordance with the above law.

■ No part of this publication may be reproduced or transmitted in any form or by any means, electronic or mechanical, including photocopying and recording, or any information storage or retrieval system, or otherwise, without the prior written consent of SANYO Semiconductor Co.,Ltd.

■ Any and all information described or contained herein are subject to change without notice due to product/technology improvement, etc. When designing equipment, refer to the "Delivery Specification" for the SANYO Semiconductor Co.,Ltd. product that you intend to use.

■ Information (including circuit diagrams and circuit parameters) herein is for example only; it is not guaranteed for volume production.

■ Upon using the technical information or products described herein, neither warranty nor license shall be granted with regard to intellectual property rights or any other rights of SANYO Semiconductor Co.,Ltd. or any third party. SANYO Semiconductor Co.,Ltd. shall not be liable for any claim or suits with regard to a third party's intellectual property rights which has resulted from the use of the technical information and products mentioned above.



●SANYO Semiconductor Co.,Ltd. Website

[http://www.semic.sanyo.co.jp/index\\_e.htm](http://www.semic.sanyo.co.jp/index_e.htm)

This catalog provides information as of June, 2008.  
Specifications and information herein are subject to change without notice.

**SANYO**

**SANYO Semiconductor Co., Ltd.**